

5

3.5X16
K1 x6
300mm.
T1 x1

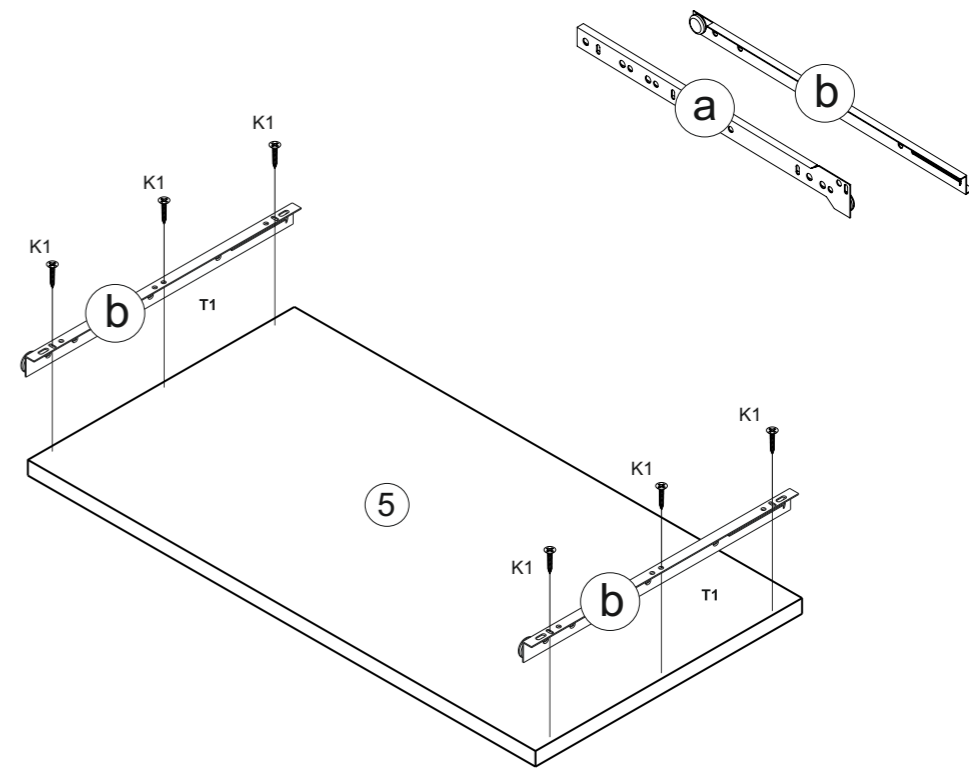

6

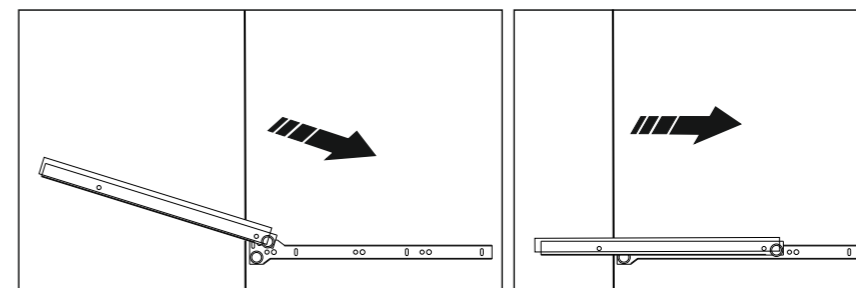
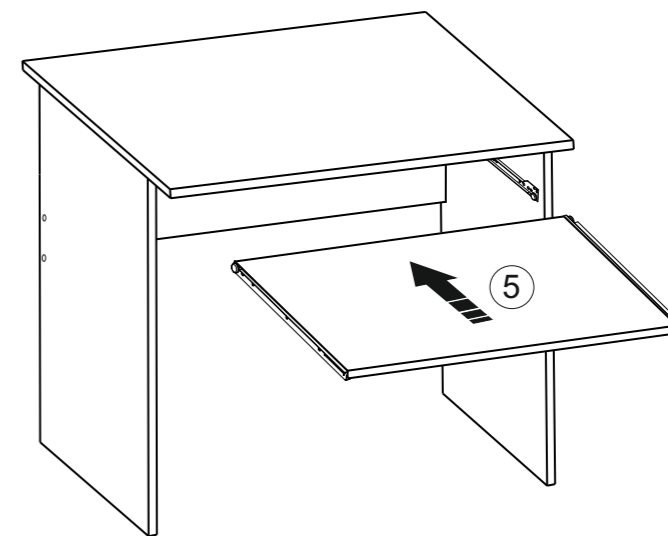

3

MB x4

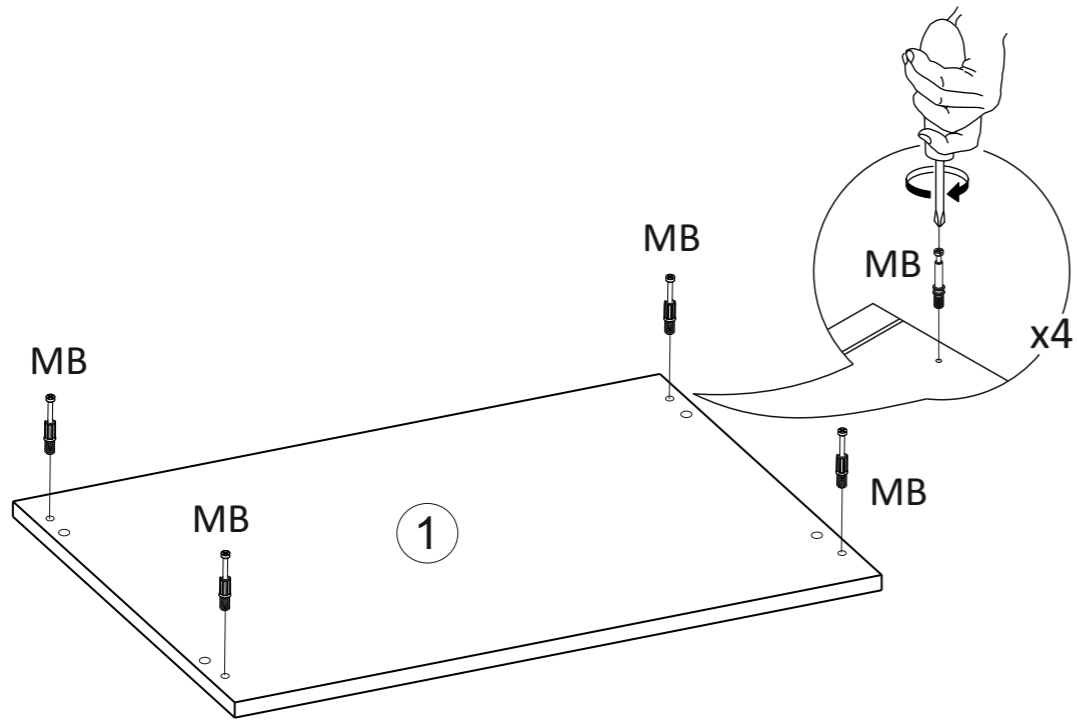

4

Mz x4

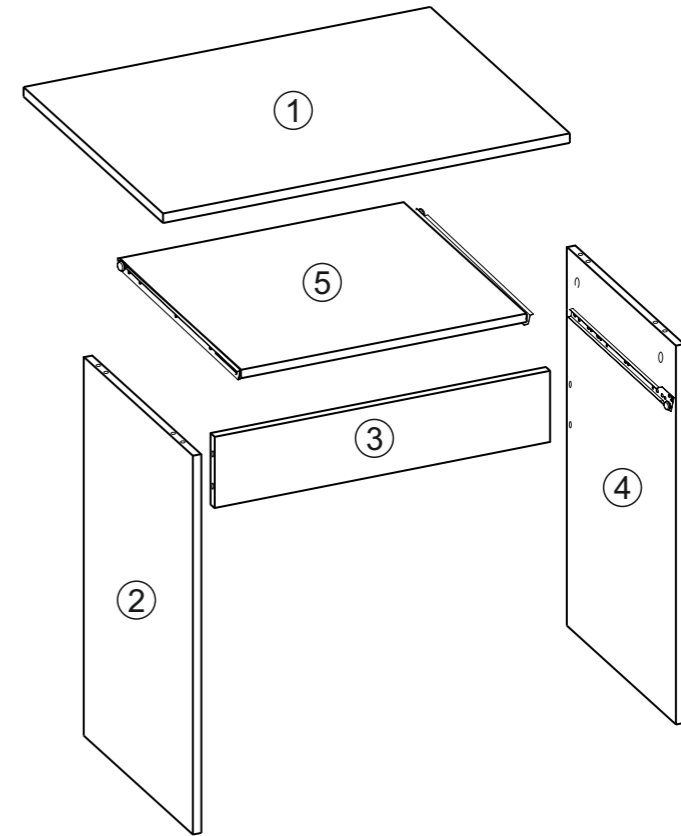
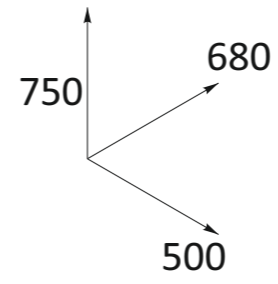
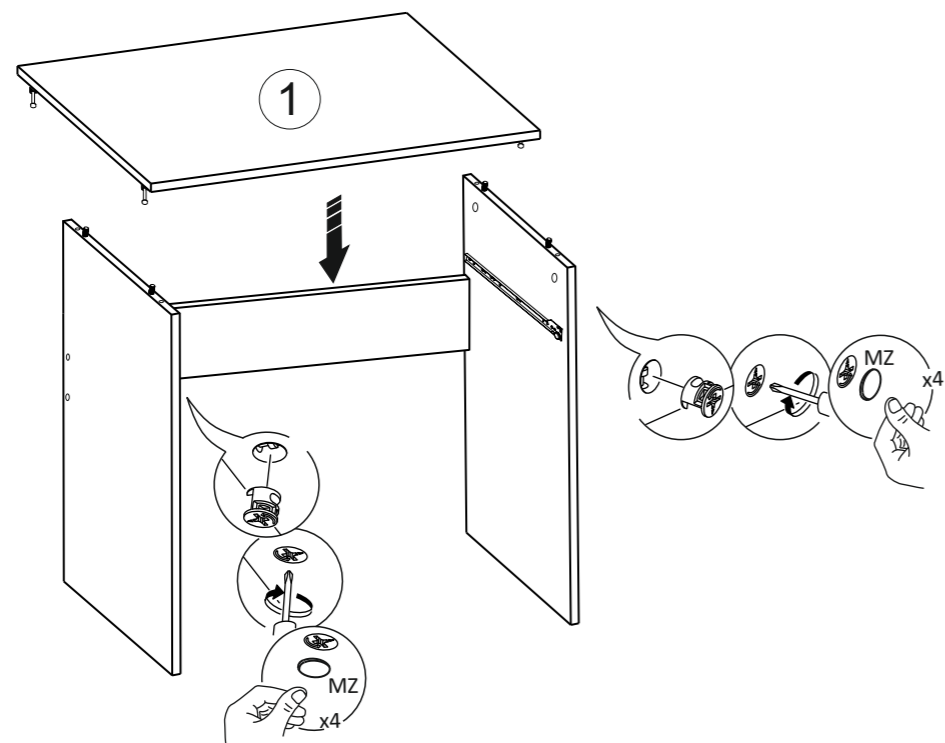

①	x1	680mm	500mm	16mm
②	x1	730mm	444mm	16mm
③	x1	628mm	150mm	16mm

④	x1	730mm	444mm	16mm
⑤	x1	603mm	300mm	16mm

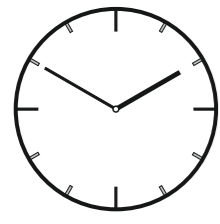

2 h

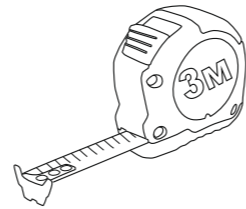
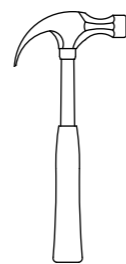
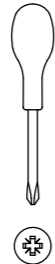
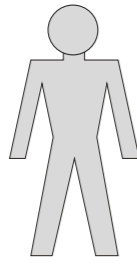

8X30

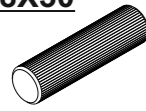

I x4

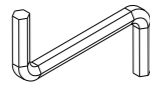

KK x1

3.5X16



K1 x6

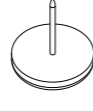

N x4

5.0X13



K3 x4

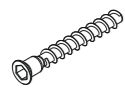

K x4



Kz x4

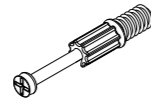

MB x4



M x4



Mz x4

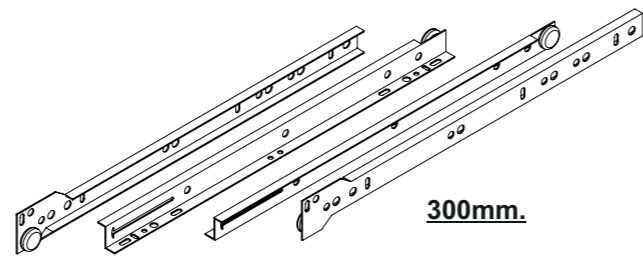
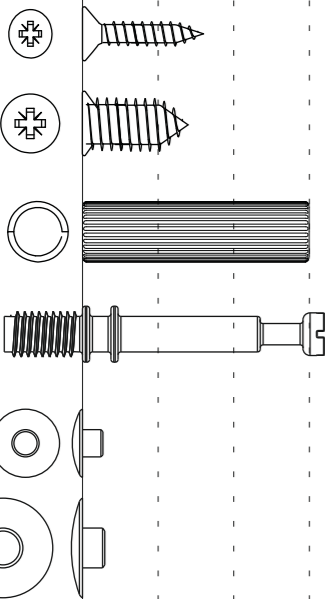
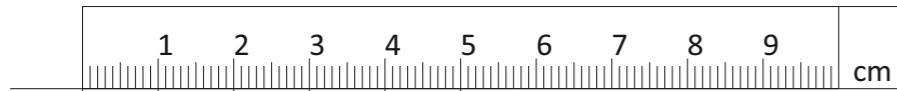

T1 x1

1



I x4



M x4



N x4



300mm.
T1 x1



K3 x4

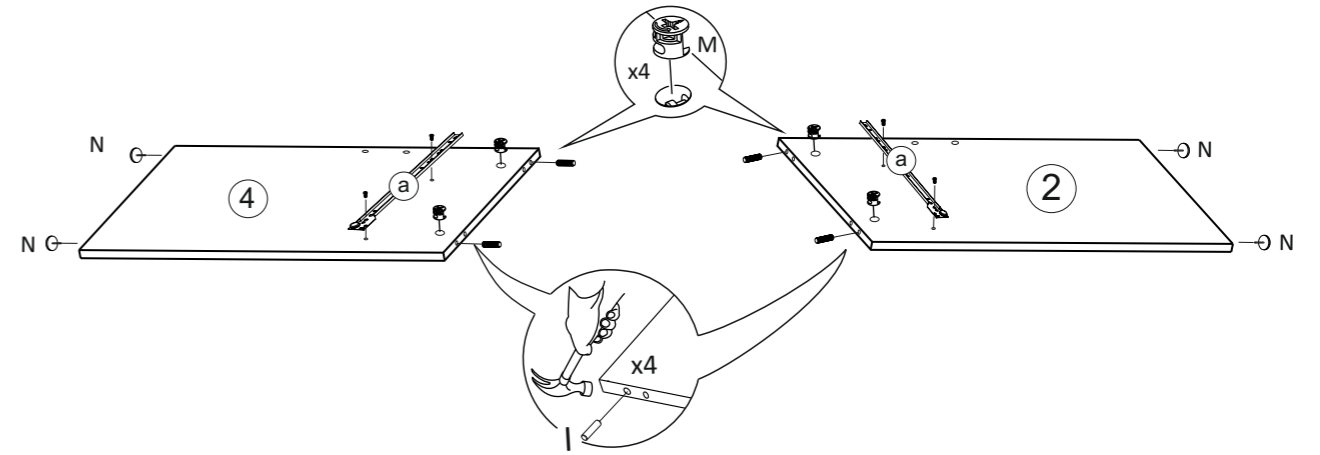
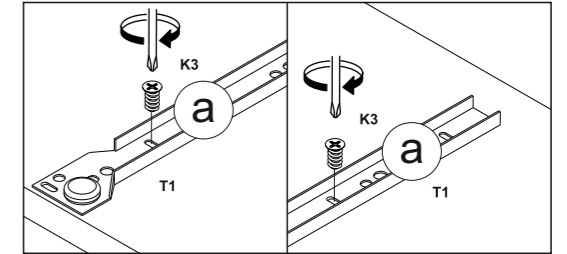
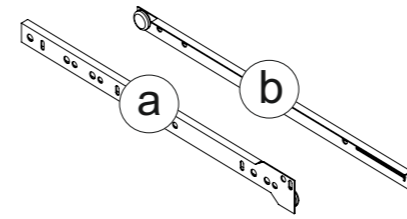

2



K x4



KK x1



Kz x4

