

finori GmbH  
Straßäcker 2  
D - 96253 Untersiemau

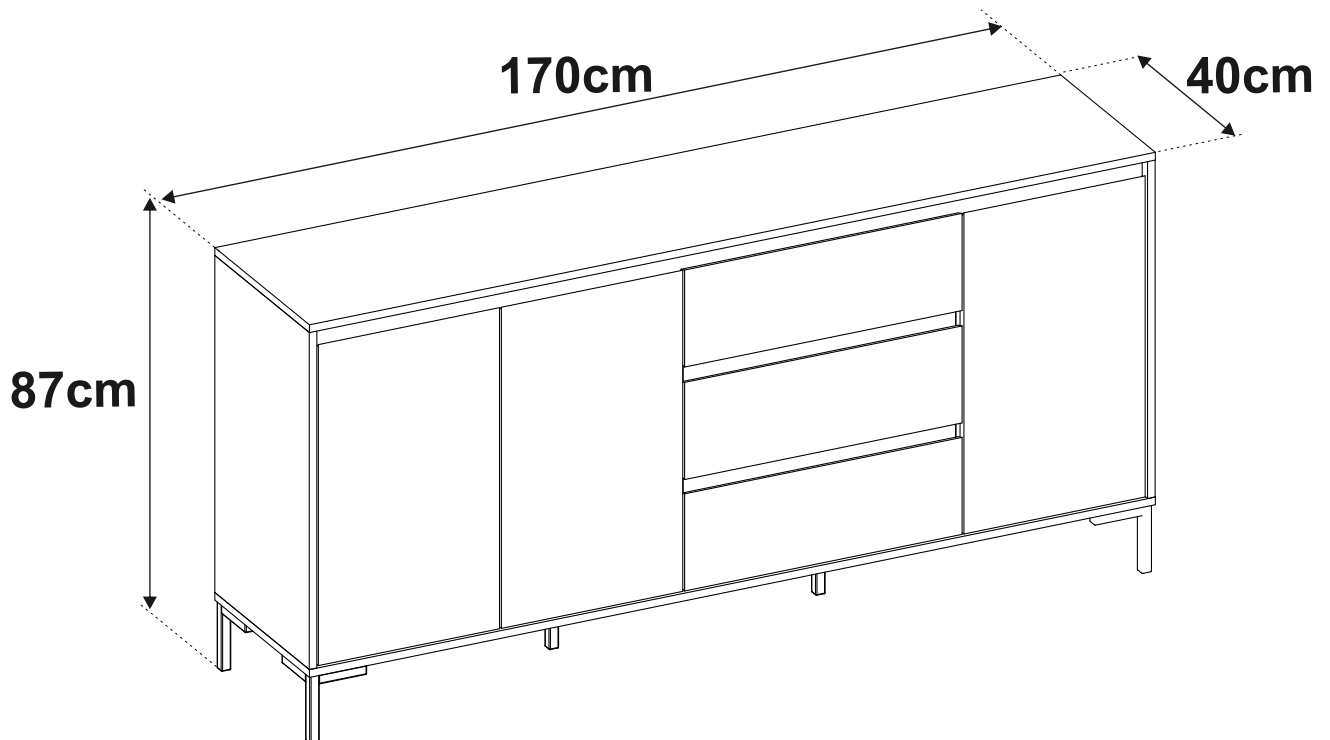

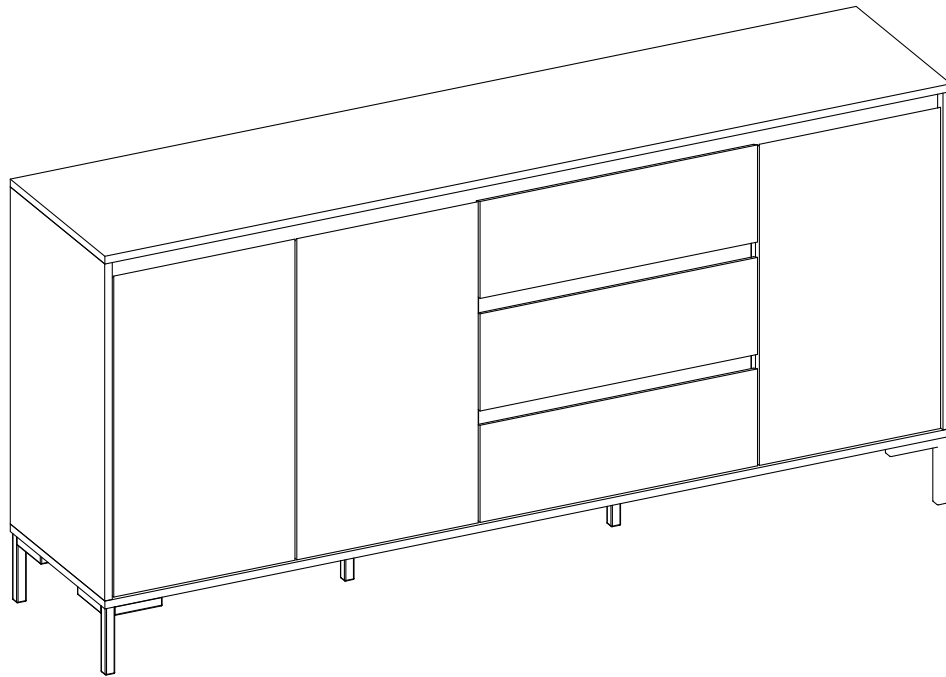
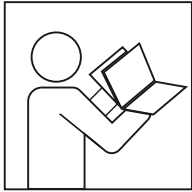

- Ⓓ Befolgen Sie stets die Anleitung des Herstellers!
- ⒸⒹ Please generally follow the manufacturers instructions!
- ⒻⒼ Suivez toujours les instructions du fabricant!
- ⒶⒻ Volg steeds de handleiding van de producent!
- ⒺⒶ Siga siempre las instrucciones del fabricante!
- ⒶⒻ Stale przestrzegaj instrukcji producenta!

- ⒶⒶ Всегда следуйте инструкции производителя!
- ⒶⒶ Seguire sempre le istruzioni del produttore!
- ⒶⒶ Mindig tartsa be a gyártó utasításait!
- ⒶⒶ Siga sempre as instruções do fabricante!
- ⒶⒶ Vždy dodržujte pokyny výrobce!

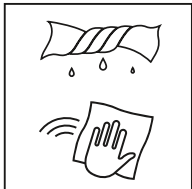

- Ⓓ Verwenden Sie zur Reinigung nur ein feuchtes Tuch!
- ⒸⒹ Please only clean with a damp cloth!
- ⒻⒼ N'utilisez qu'un chiffon humide pour le nettoyage!
- ⒶⒻ Gebruik voor de reiniging enkel een vochtige doek!
- ⒺⒶ Para limpiar utilice sólo un paño húmedo!
- ⒶⒻ Do czyszczenia używaj wilgotnej szmatki!

- ⒶⒶ Для очистки используйте только влажную ткань!
- ⒶⒶ Per la pulizia, utilizzare solo un panno umido!
- ⒶⒶ A tisztításhoz elegendő egy nedves kendő használatát!
- ⒶⒶ Para a limpeza use apenas um pano húmido!
- ⒶⒶ Pro čištění používejte pouze vlhký hadřík!

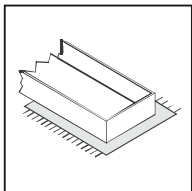

- Ⓓ Bauen Sie das Produkt auf einer Unterlage auf!
- ⒸⒹ Please mount the product on a bottom support!
- ⒻⒼ Montez le produit sur une base!
- ⒶⒻ Monteer het product op een basis!
- ⒺⒶ Monte el producto sobre una base!
- ⒶⒻ Rozkładaj produkt na podkładce!

- ⒶⒶ Собирайте изделие на подстилке!
- ⒶⒶ Montare il prodotto su un supporto!
- ⒶⒶ Az összeszereléskor helyezzen a termék alá megfelelő alátétet!
- ⒶⒶ Monte o produto numa superfície plana!
- ⒶⒶ Výrobek smontujte na pevném podkladu!

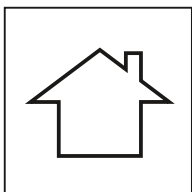

- Ⓓ Verwenden Sie das Produkt nur in Innenräumen!
- ⒸⒹ Please exclusively use the product indoors!
- ⒻⒼ N'utilisez le produit qu'à l'intérieur!
- ⒶⒻ Gebruik het product enkel binnenshuis!
- ⒺⒶ Utilice el producto sólo en interiores!
- ⒶⒻ Używaj produkt tylko w pomieszczeniach wewnętrznych!

- ⒶⒶ Используйте изделие только во внутренних помещениях!
- ⒶⒶ Utilizzare il prodotto solo in ambienti interni!
- ⒶⒶ A termék csak bel terekben használható!
- ⒶⒶ Use o produto apenas no interior!
- ⒶⒶ Používejte výrobek pouze uvnitř!

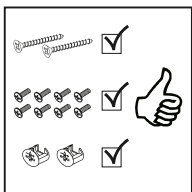

- Ⓓ Legen Sie die Beschläge zusammen und prüfen Sie die Vollständigkeit!
- ⒸⒹ Please join the fittings and verify their completeness!
- ⒻⒼ Pliez les raccords ensemble et vérifiez qu'ils sont complets!
- ⒶⒻ Leg de onderdelen samen en controleer de volledigheid!
- ⒺⒶ Junte los accesorios y compruebe que están todos!
- ⒶⒻ Rozłóż poszczególne części i sprawdź kompletność!

- ⒶⒶ Положите фурнитуру в одно место и проверьте комплектности!
- ⒶⒶ Mettere insieme le guarnizioni e verificarne la completezza!
- ⒶⒶ Állítsa össze a sarokvasakat, és ellenőrizze, hogy épek-e!
- ⒶⒶ Coloque os encaixes juntos e verifique se estão completos!
- ⒶⒶ Složte armatury a zkontrolujte úplnost!



- Ⓓ Bei fehlenden Teilen kontaktieren Sie den Hersteller!
- ⒸⒹ If parts are missing, please turn to the manufacturer!
- ⒻⒼ En cas de pièces manquantes, veuillez contacter le fabricant!
- ⒶⒻ Contacteer de fabrikant als er onderdelen ontbreken!
- ⒺⒶ En el caso de que falten piezas, póngase en contacto con el fabricante!
- ⒶⒻ W razie braku części skontaktuj się z producentem!

- ⒶⒶ При отсутствии каких-либо частей обратитесь к производителю!
- ⒶⒶ In caso di pezzi mancanti, contattare il produttore!
- ⒶⒶ Ha hiányozna valamelyik elem, lépjen kapcsolatba a gyártóval!
- ⒶⒶ Em caso de peças em falta, entre em contato com o fabricante!
- ⒶⒶ Pro chybějící díly kontaktujte výrobce!

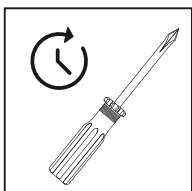

- Ⓓ Ziehen Sie die Schrauben nach einiger Zeit des Gebrauchs erneut fest!
- ⒸⒹ Please re-tighten the screws after having used the product for a while!
- ⒻⒼ Resserrer les vis après un certain temps d'utilisation!
- ⒶⒻ Draai de schroeven na een zekere gebruikstijd opnieuw vast!
- ⒺⒶ Asegure de nuevo los tornillos tras usarlo durante un tiempo!
- ⒶⒻ Po pewnym czasie użytkowania ponownie dokręć śruby!

- ⒶⒶ Спустя некоторое время использования подкрутите гайки!
- ⒶⒶ Stringere nuovamente le viti dopo un certo periodo di utilizzo!
- ⒶⒶ A használat során némi idő elteltével húzza meg újra a csavarokat!
- ⒶⒶ Reaperte os parafusos após algum tempo de uso!
- ⒶⒶ Po určité době používání rouby znovu utáhněte!

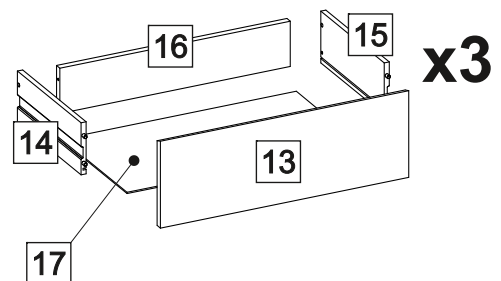
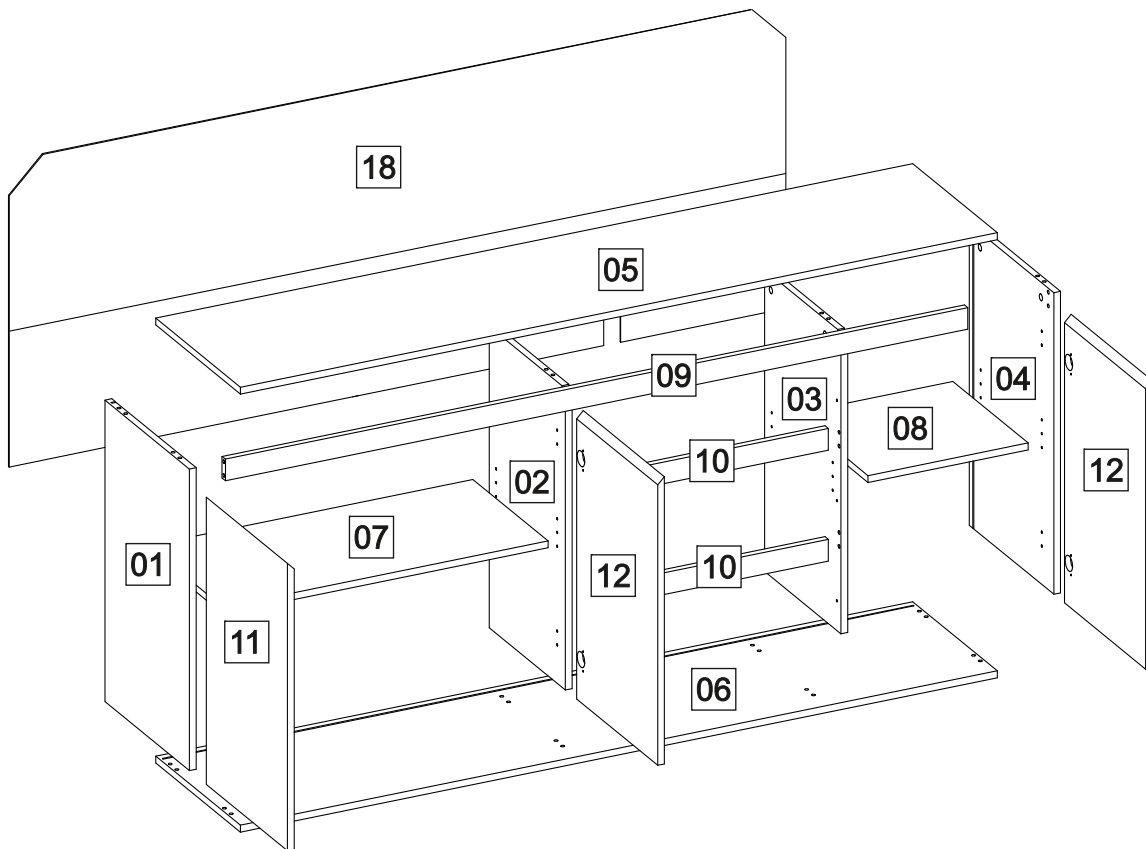
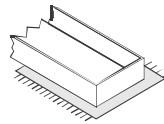
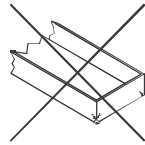
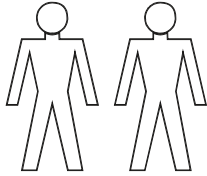
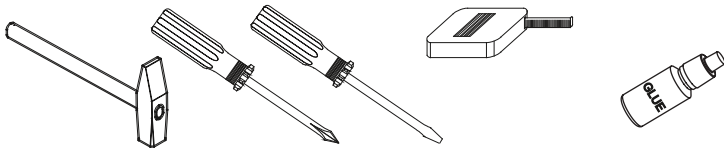

<b>BOX 1</b>	1x01; 1x02; 1x03; 1x04; 1x07; 1x08; 1x11 2x12; 3x14; 3x15; ; 4xP; 2xQ;
<b>BOX 2</b>	3x16; 1x05; 1x06;1x09; 2x10; 3x13; 1x17; 1x18

BOX 1	✓
-------	---

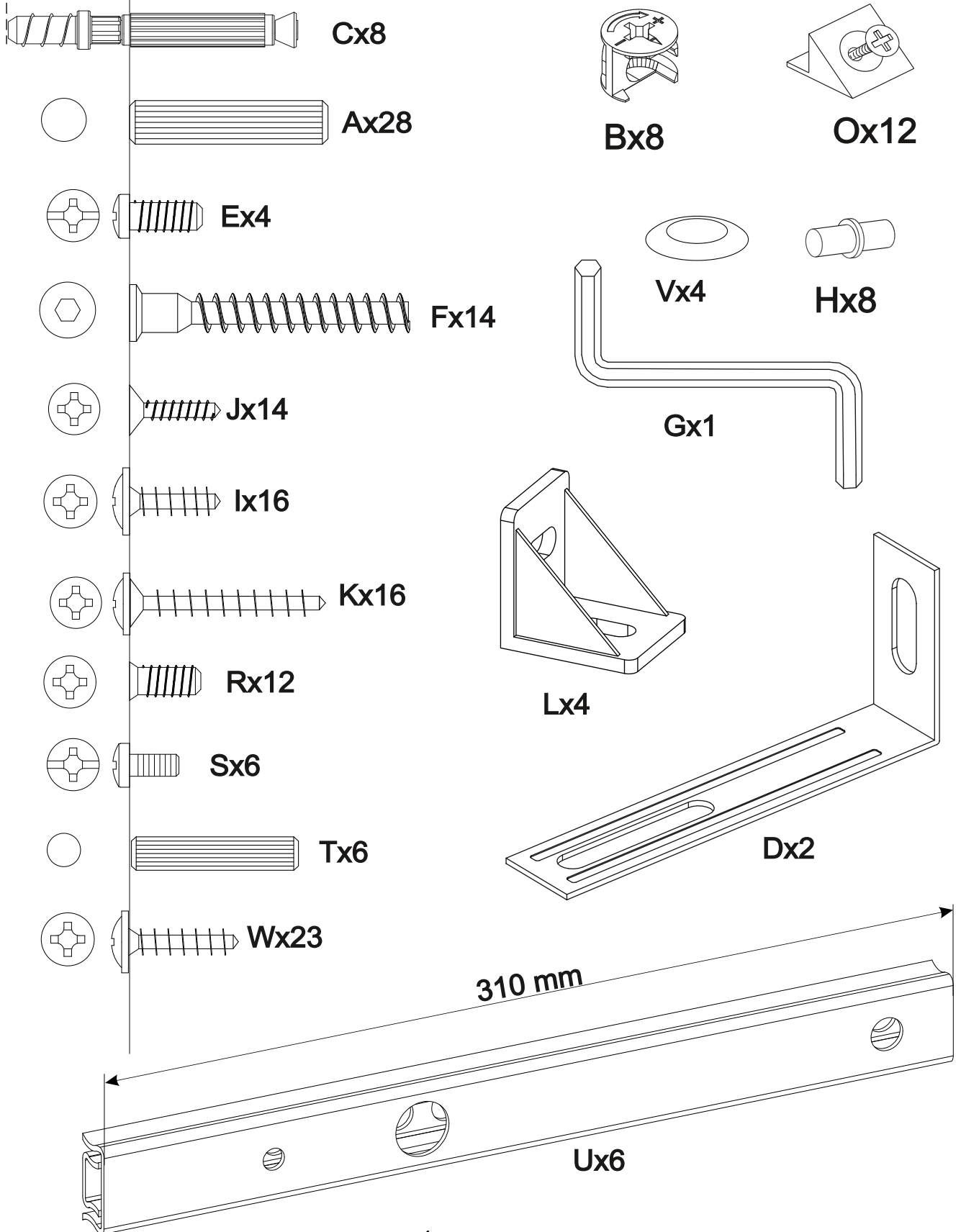
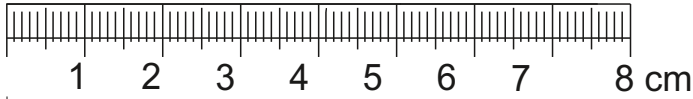

BOX 1	✓
-------	---

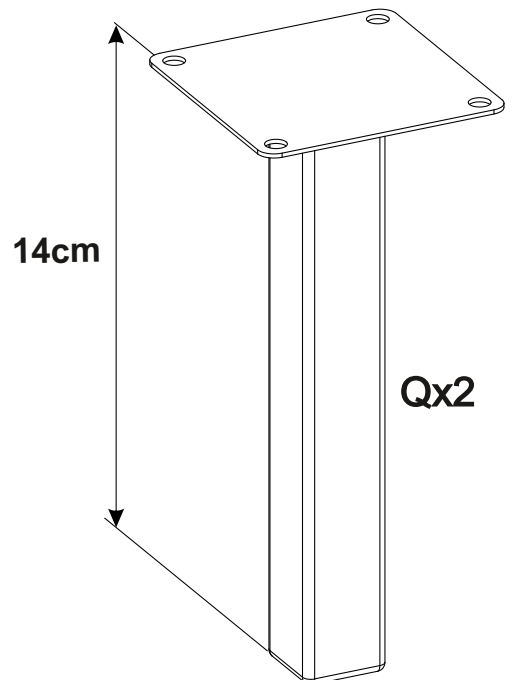
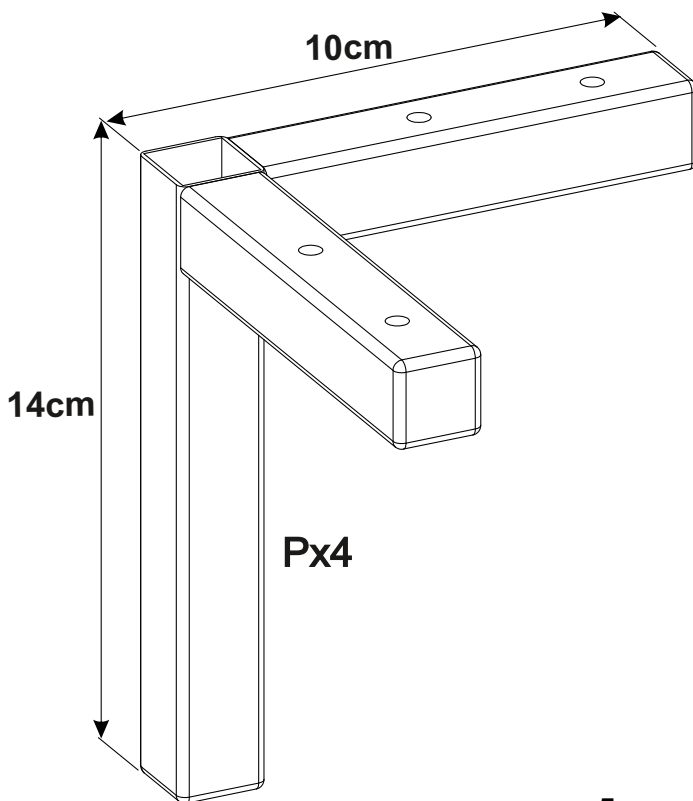
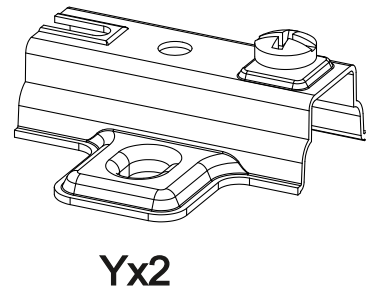
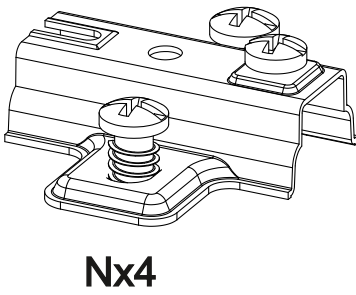
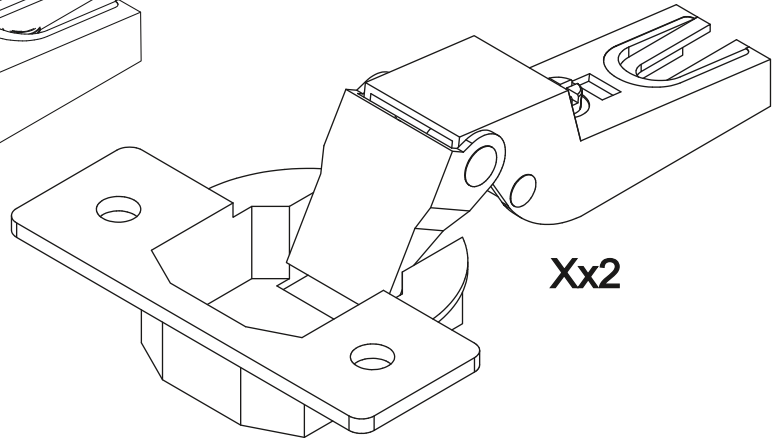
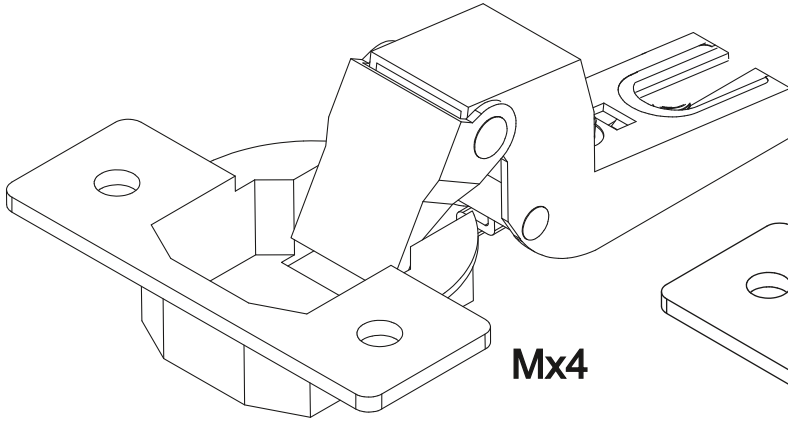
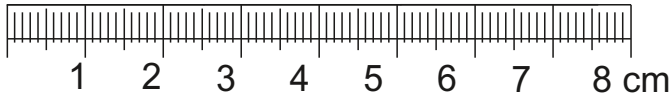

A

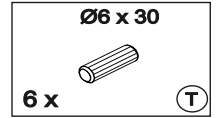
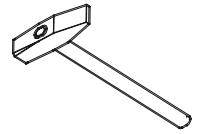
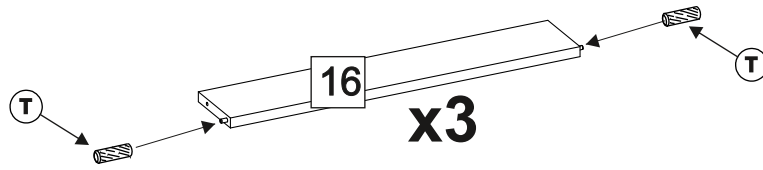

B

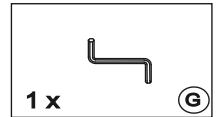
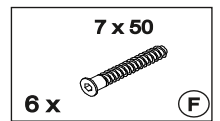
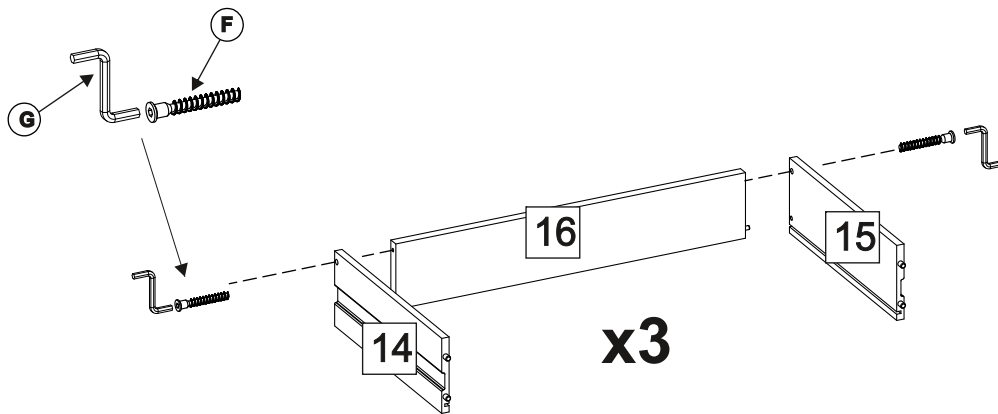

C

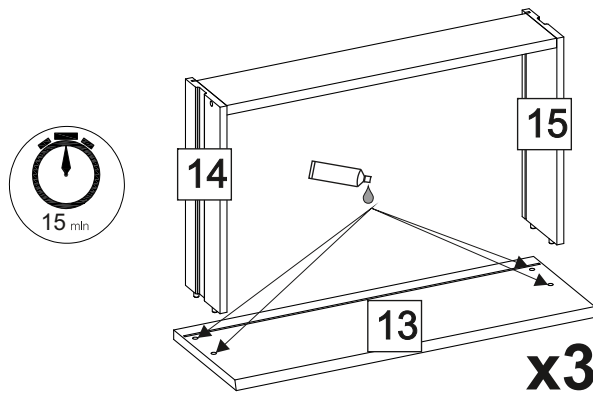

D

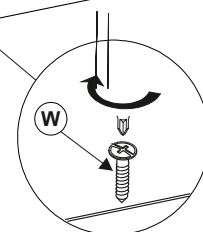
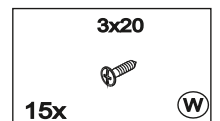
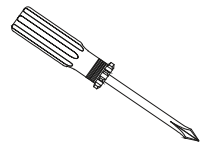
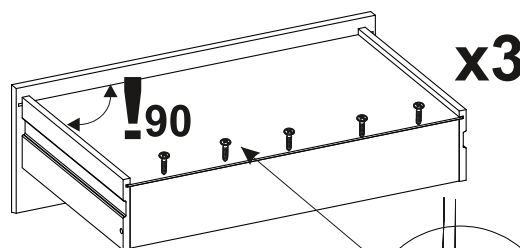
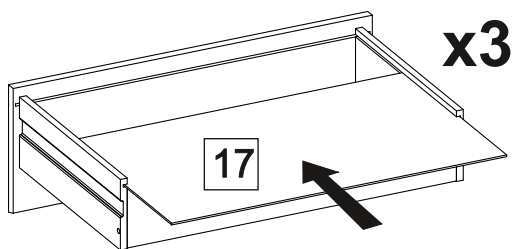

**E**

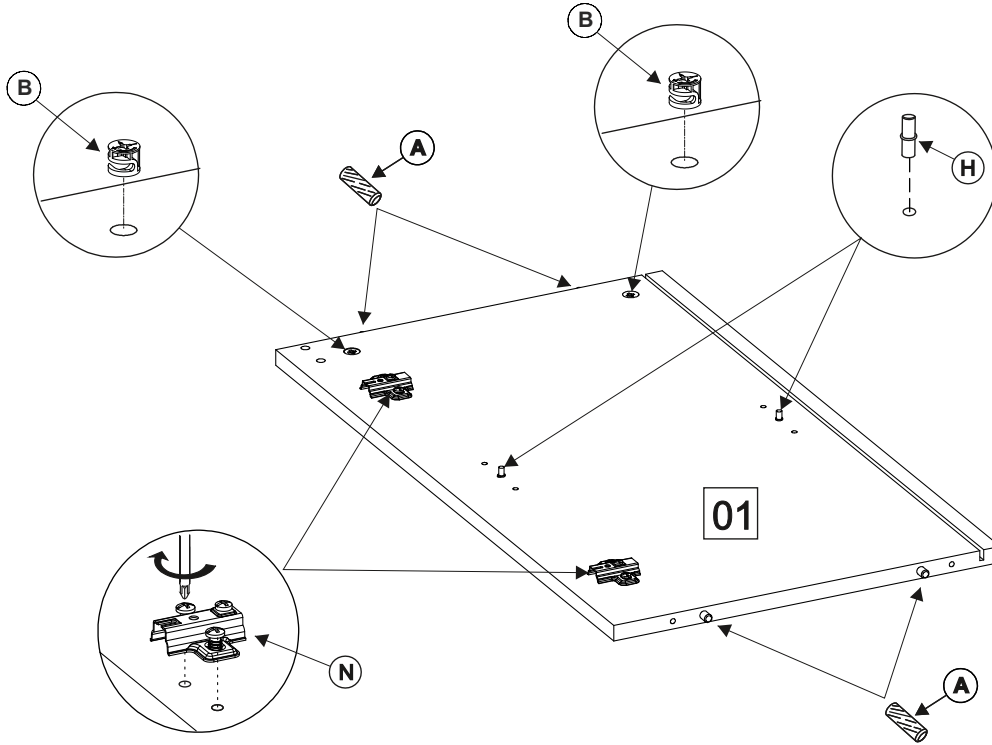
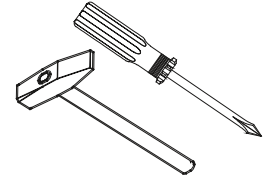
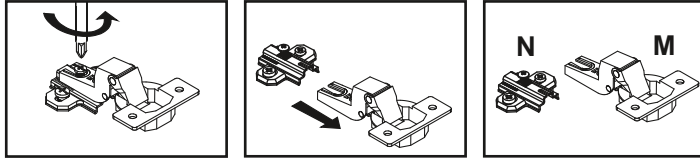

- Ø8 x 35**

4x **(A)**
- 2x **(B)**
- 2x **(H)**
- 2x **(N)**

**F**

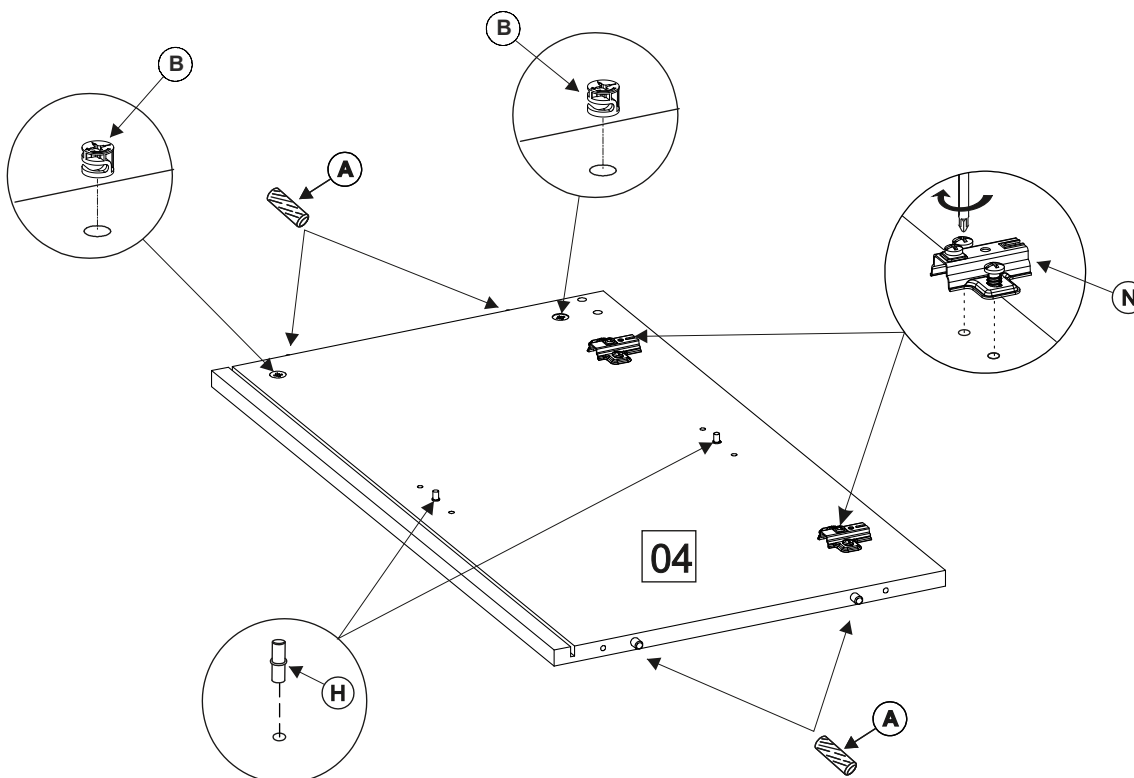
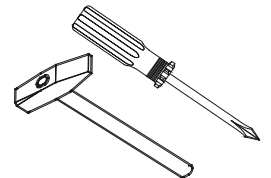
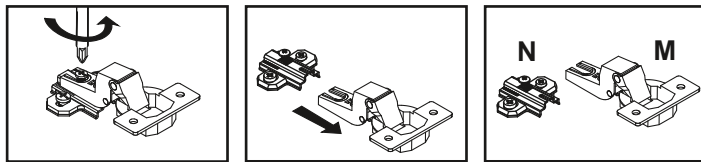

- Ø8 x 35**

4x **(A)**
- 2x **(B)**
- 2x **(H)**
- 2x **(N)**

**G**

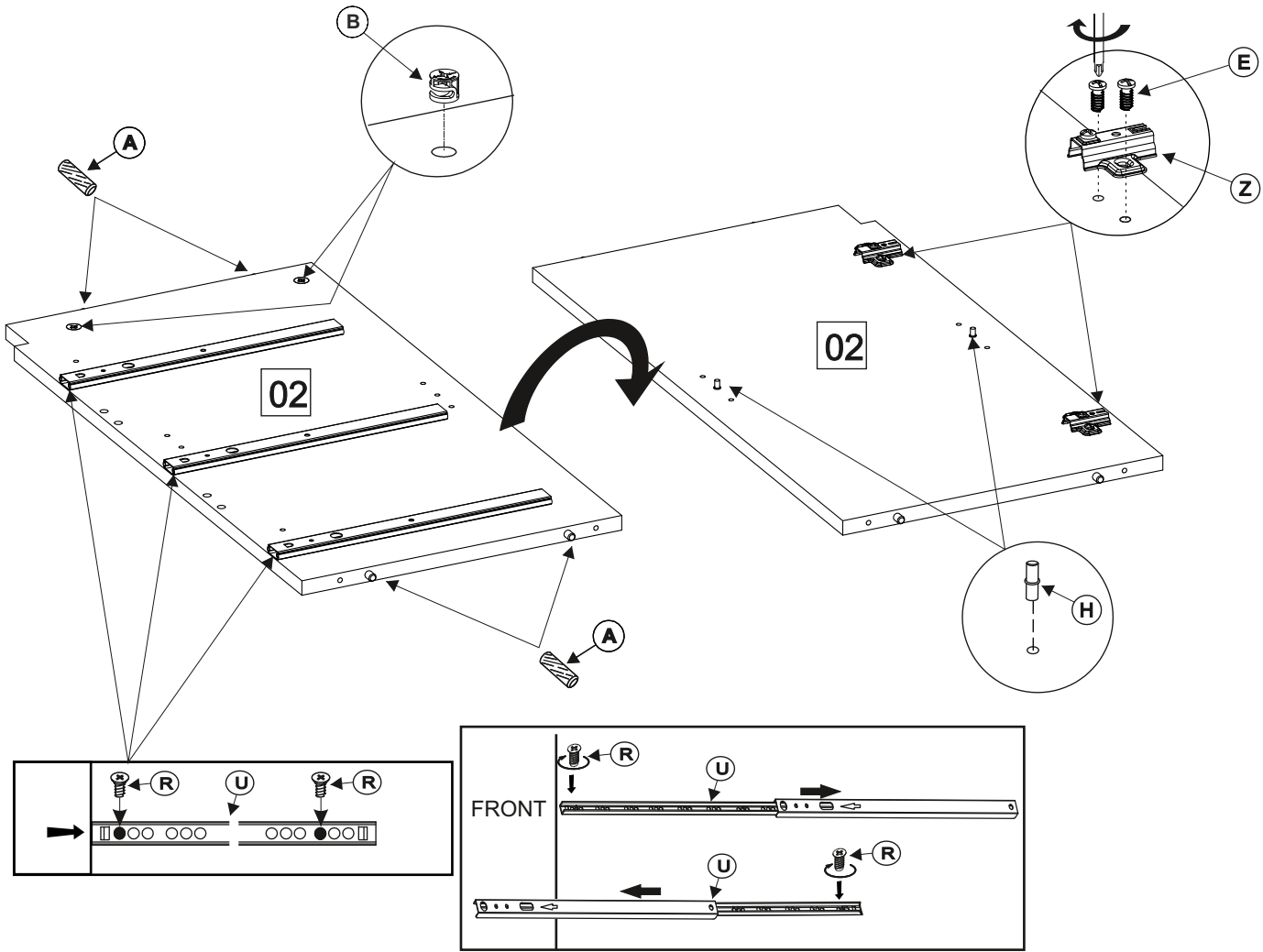
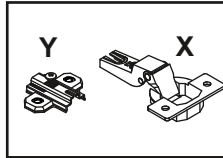
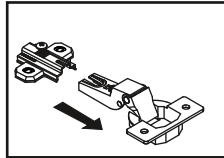
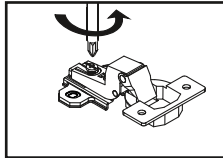
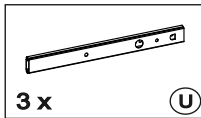
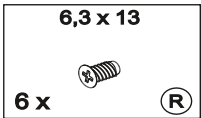
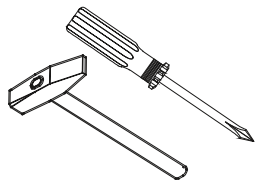
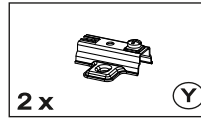
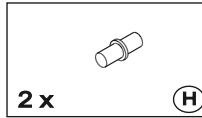
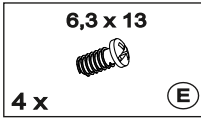
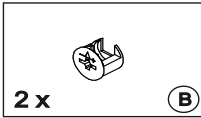
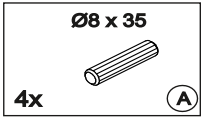

**H**

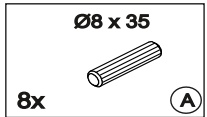
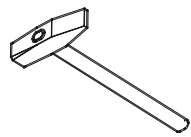
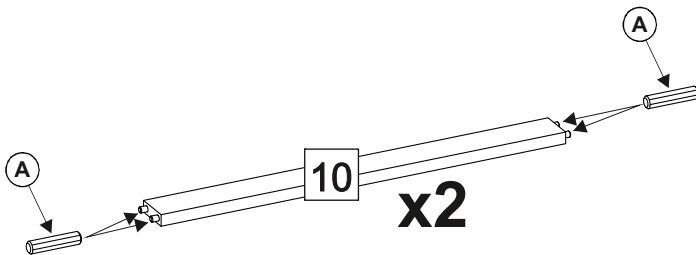



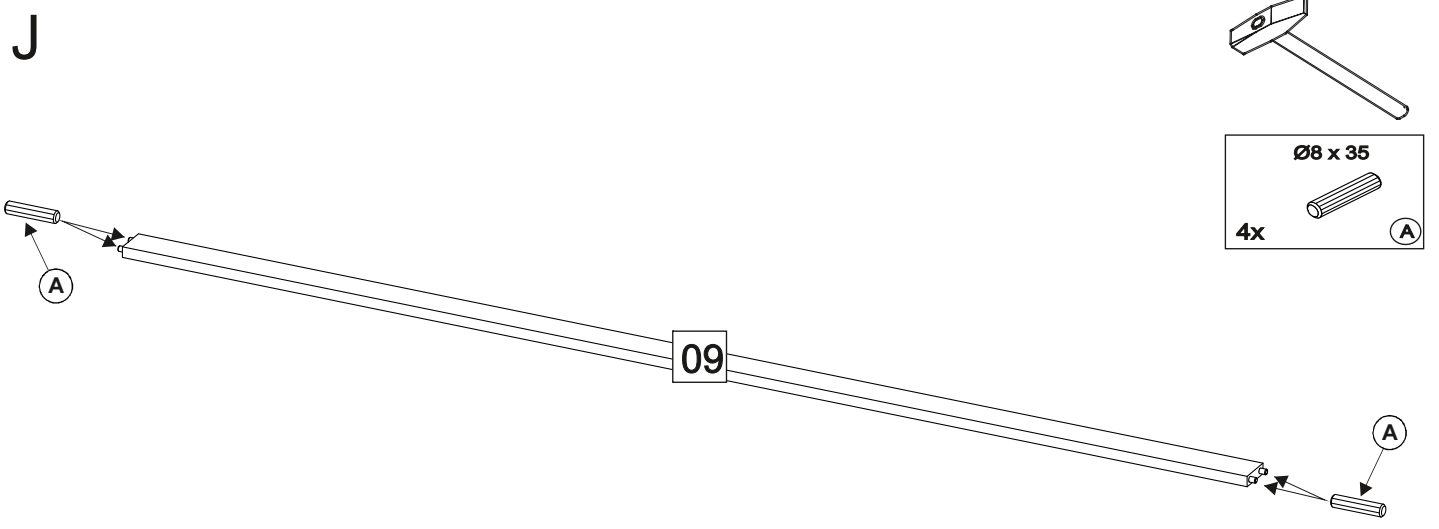
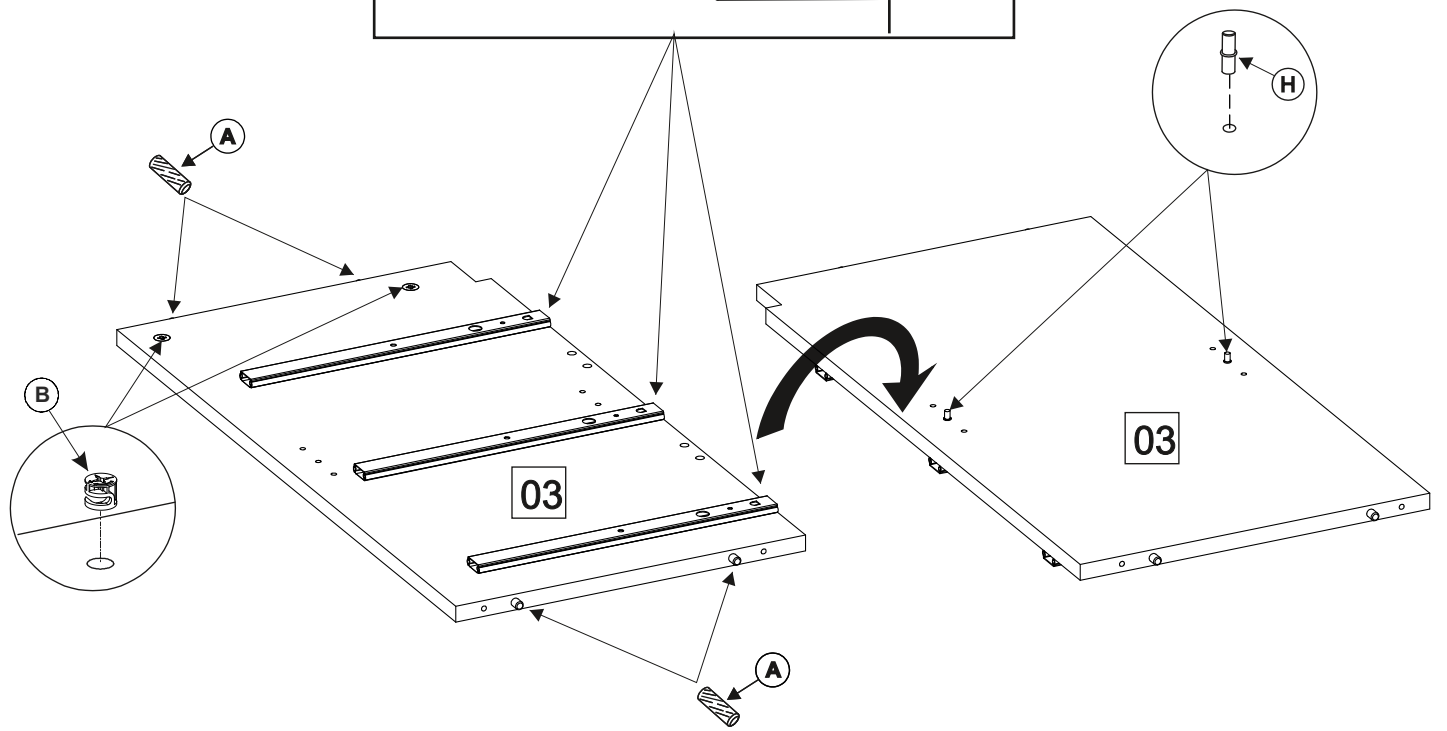
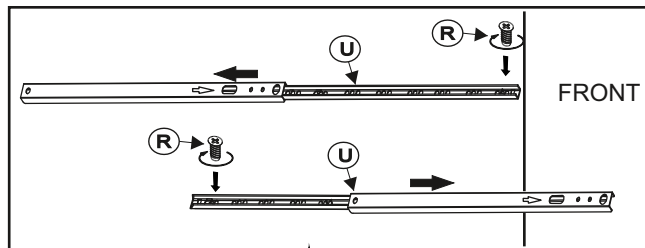
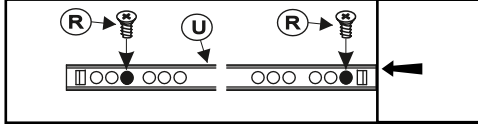
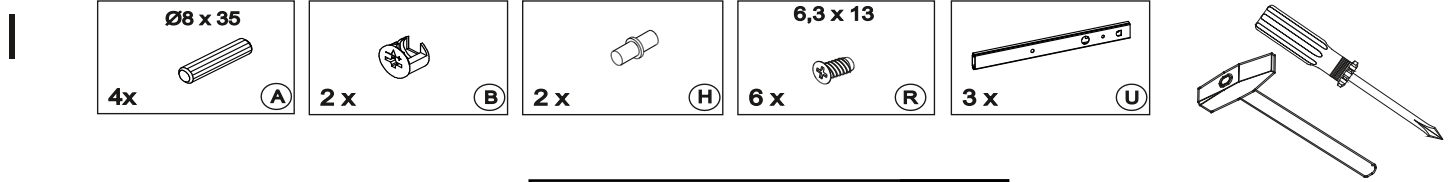

K

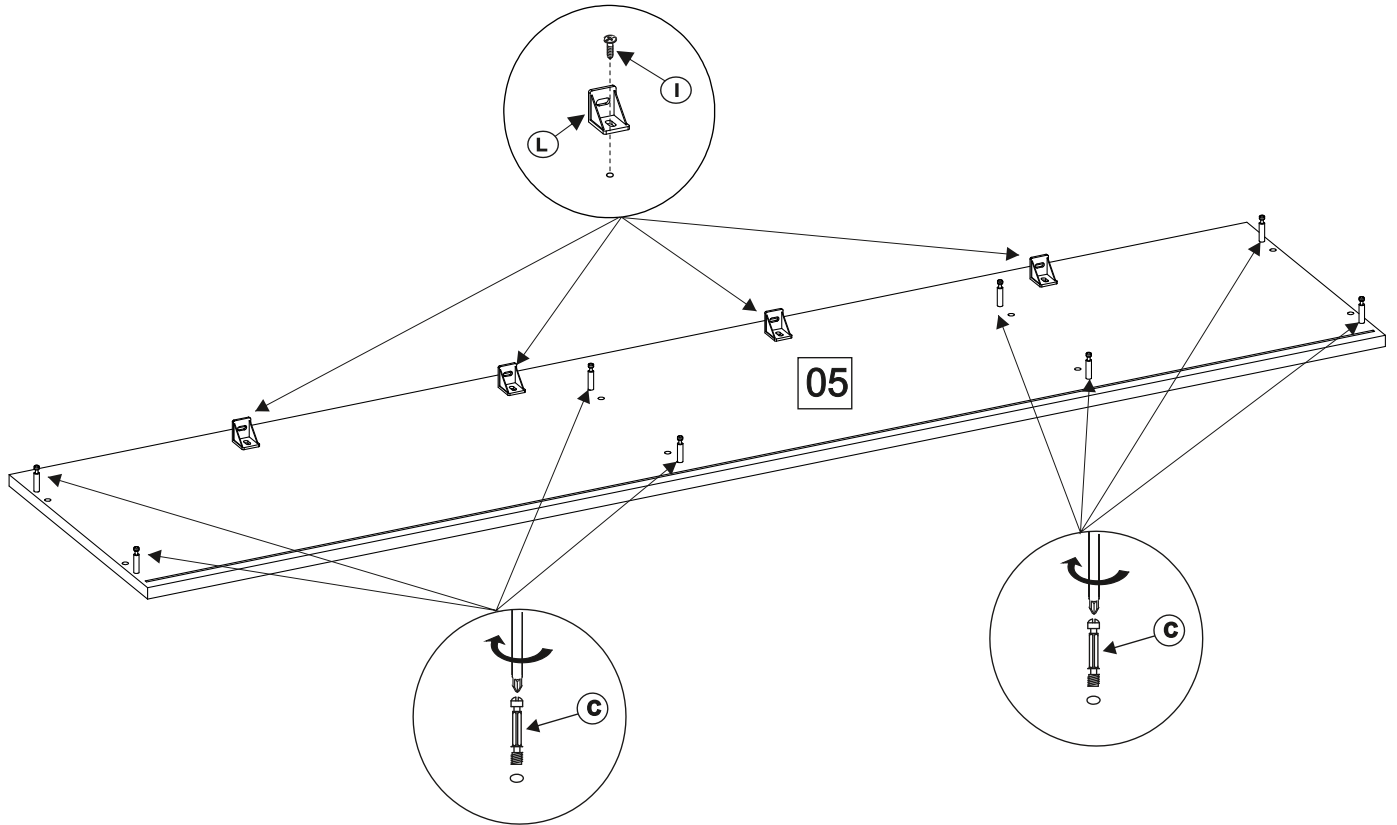
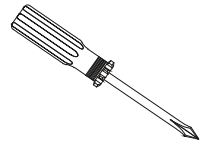
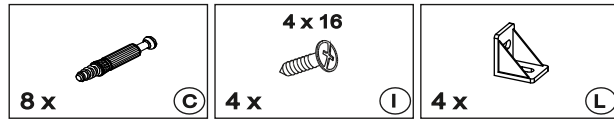

L

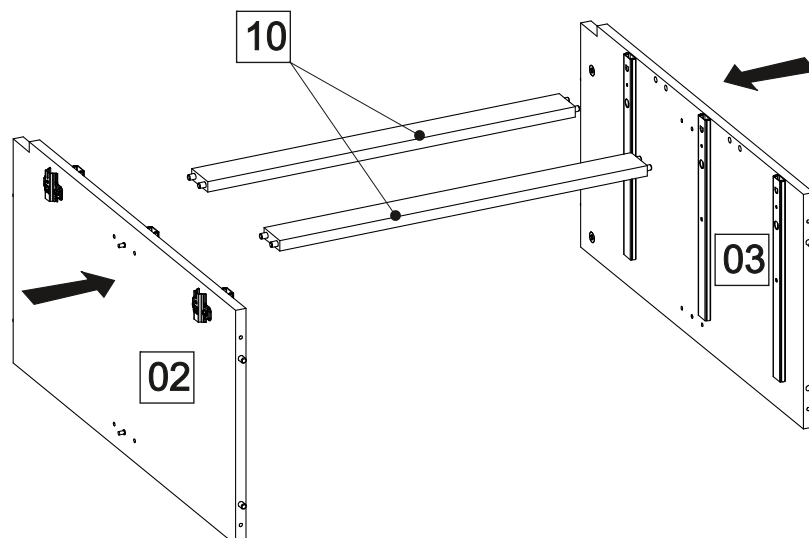
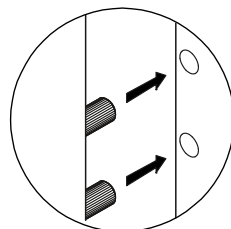

## M

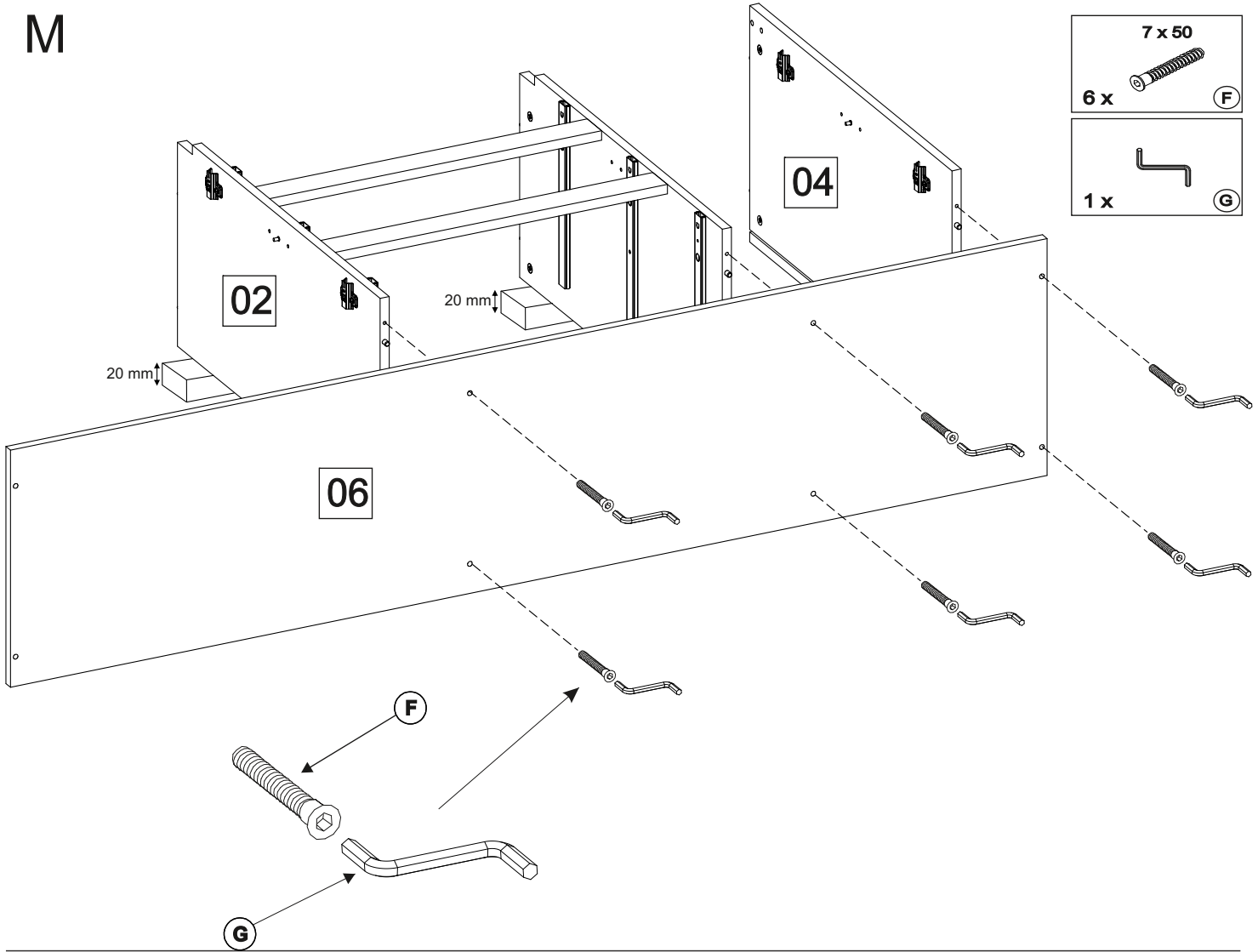

## N

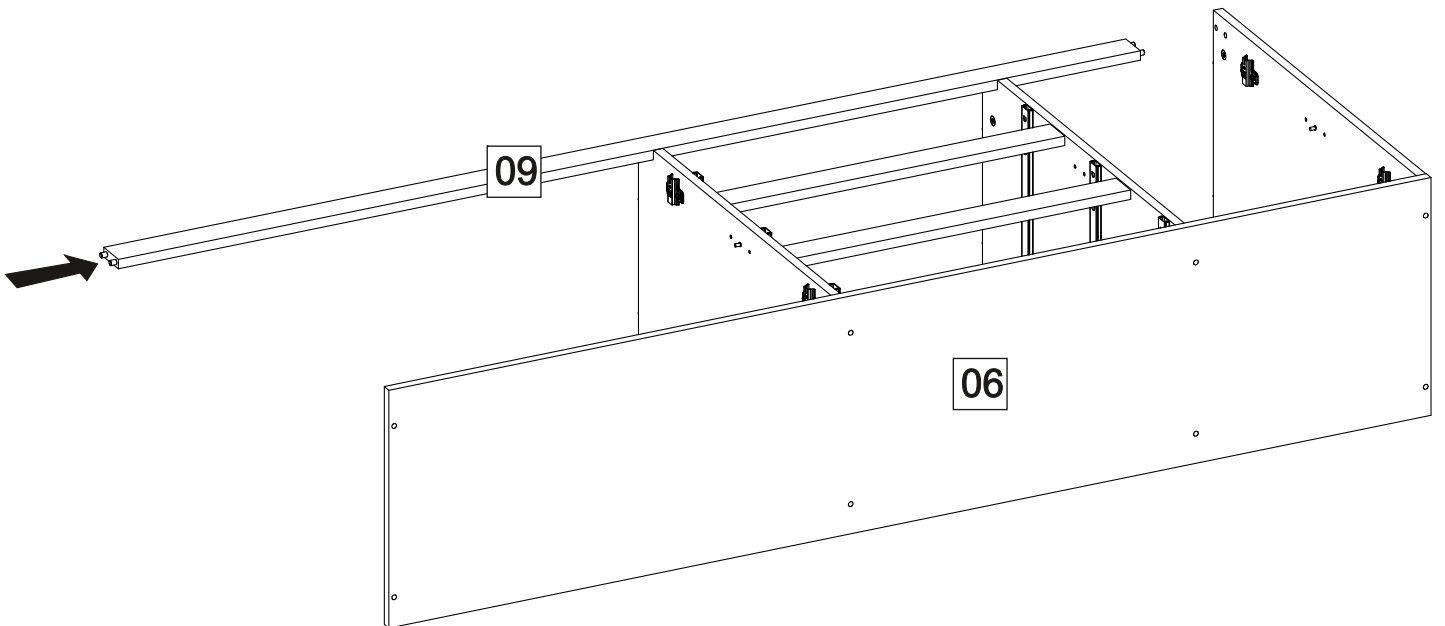

O

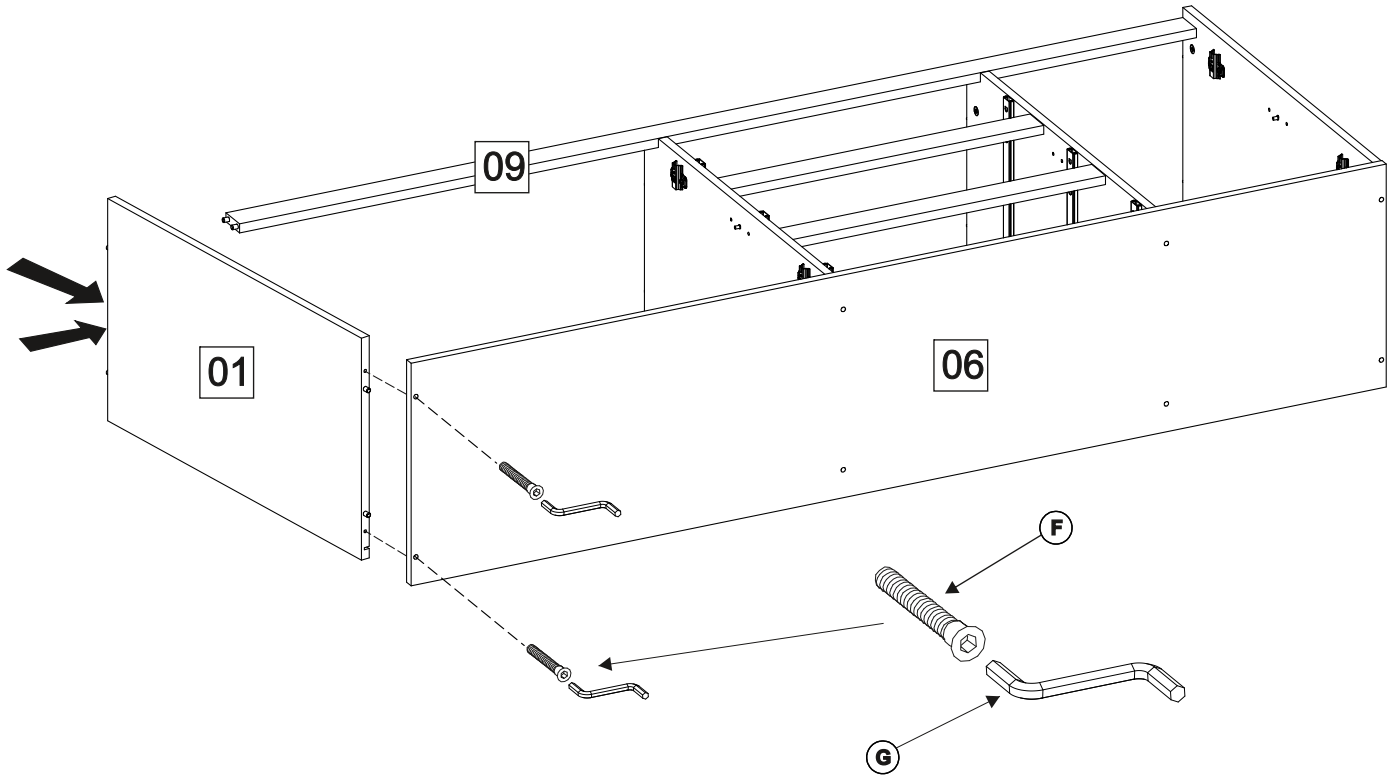
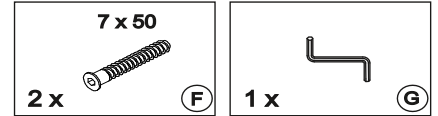

P

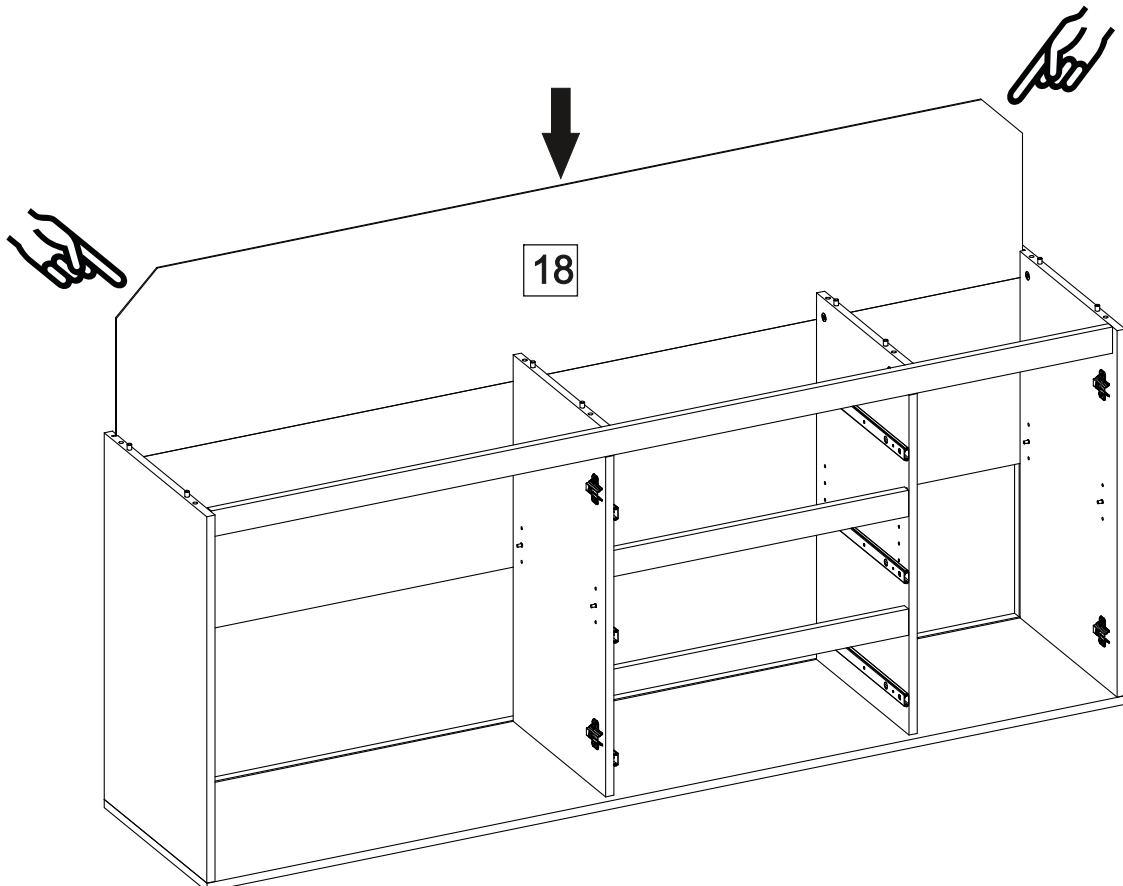

Q

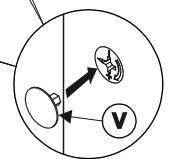
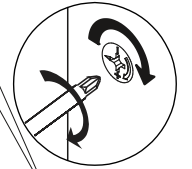
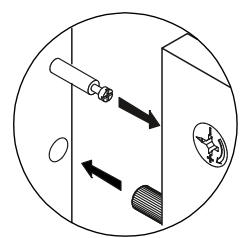
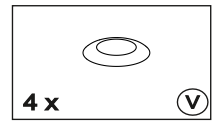
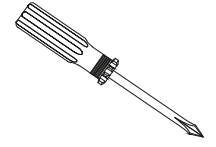
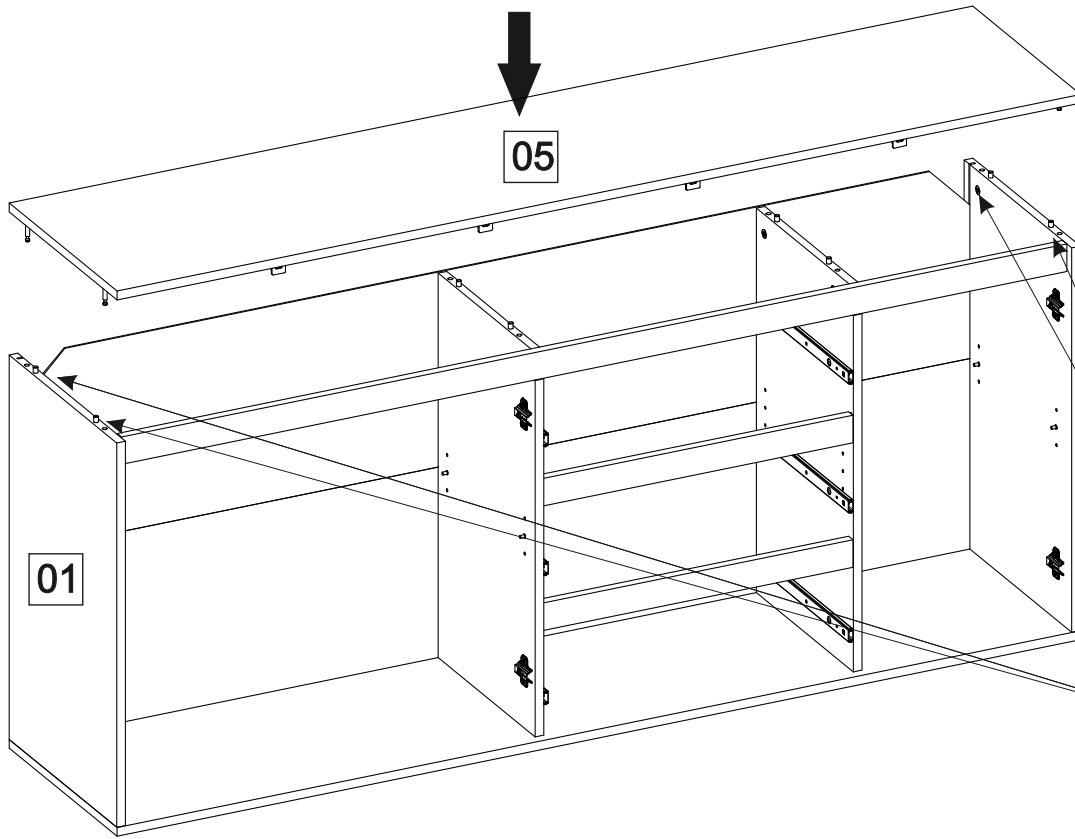

R

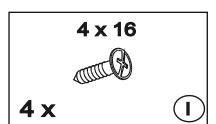
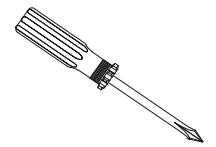
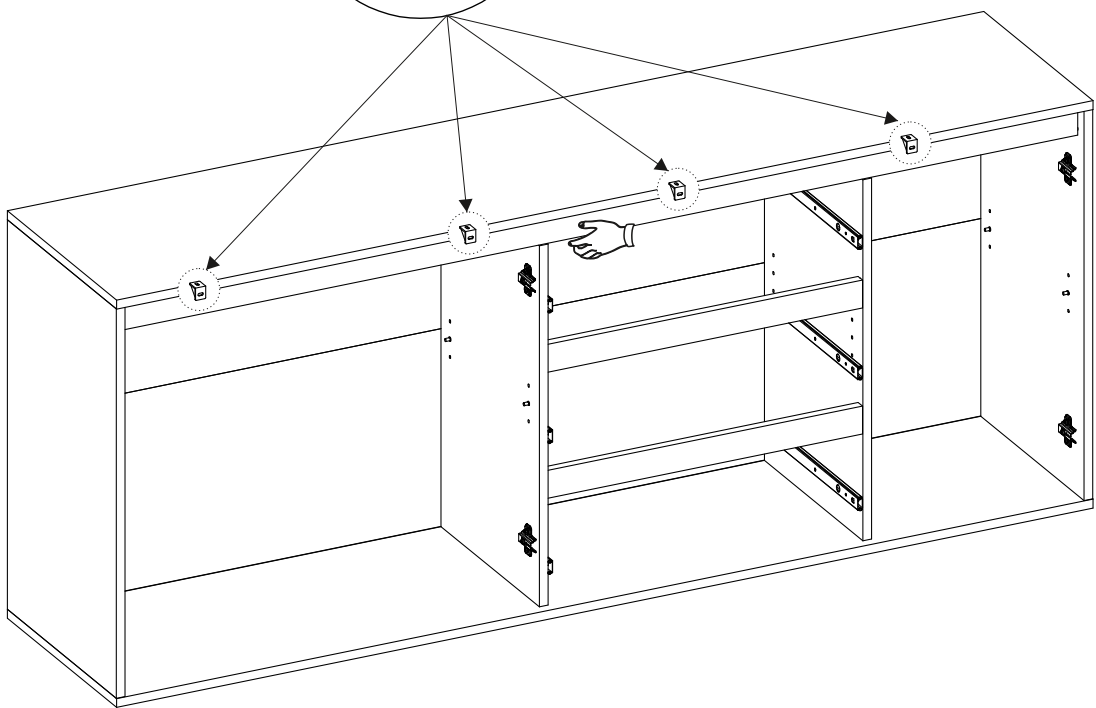
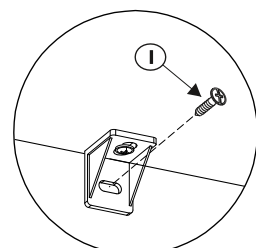

**S**

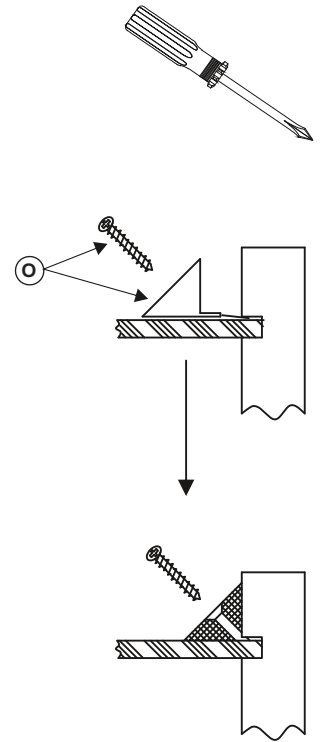
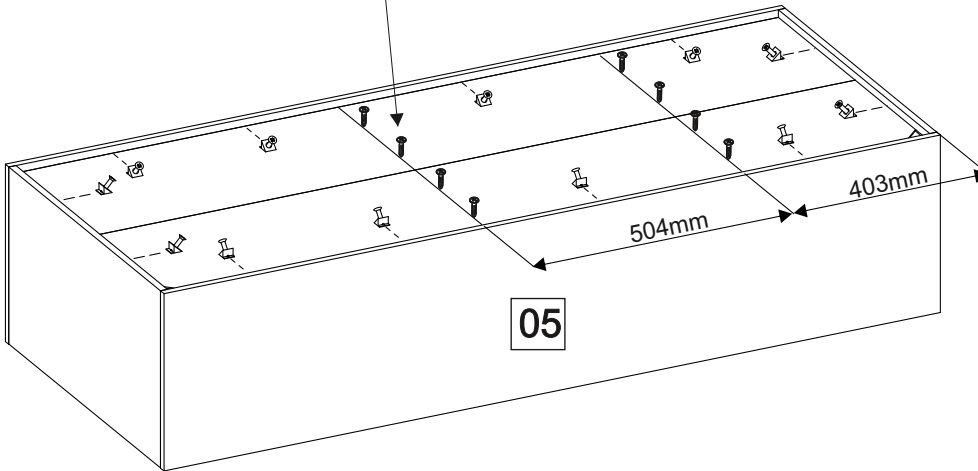
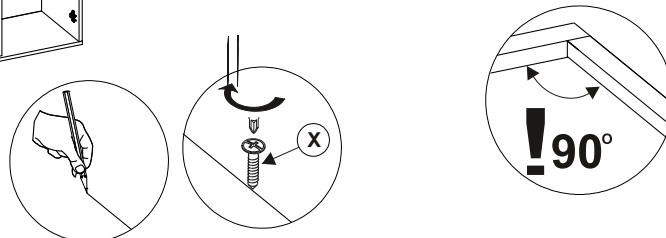
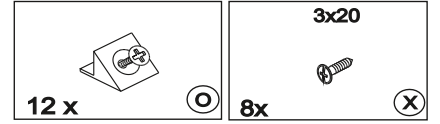
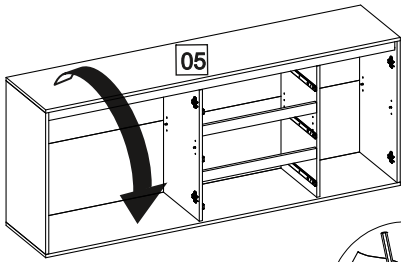

**T**

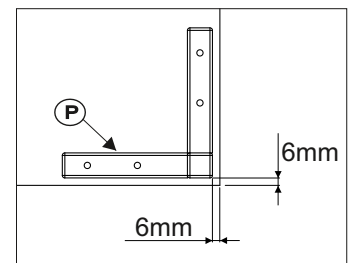
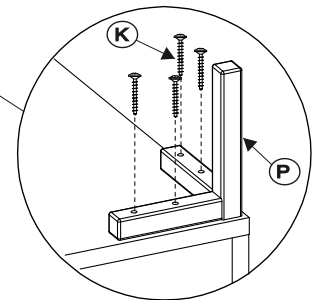
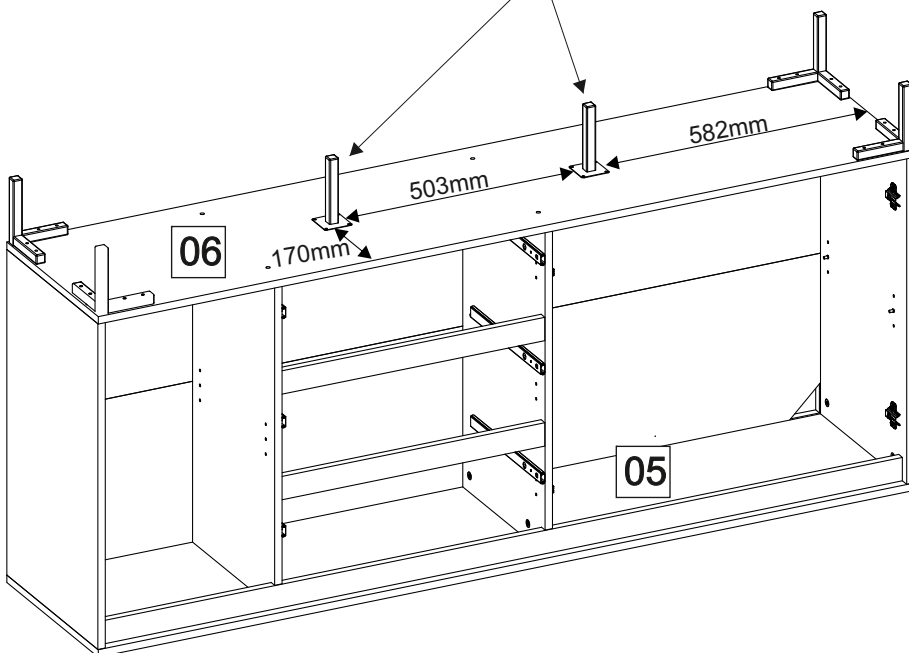
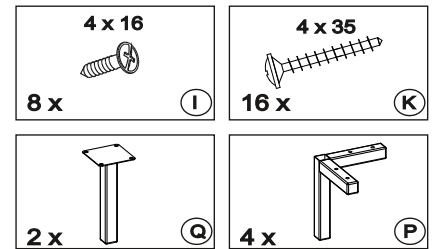
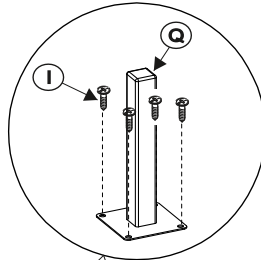
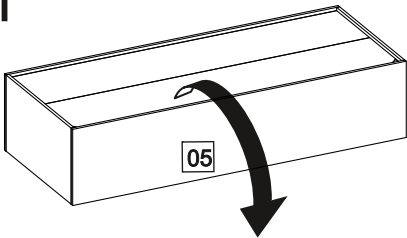

U

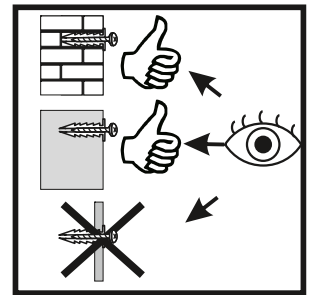
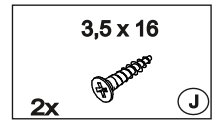
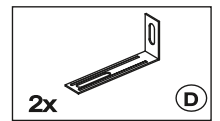
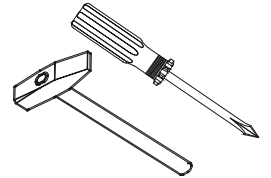
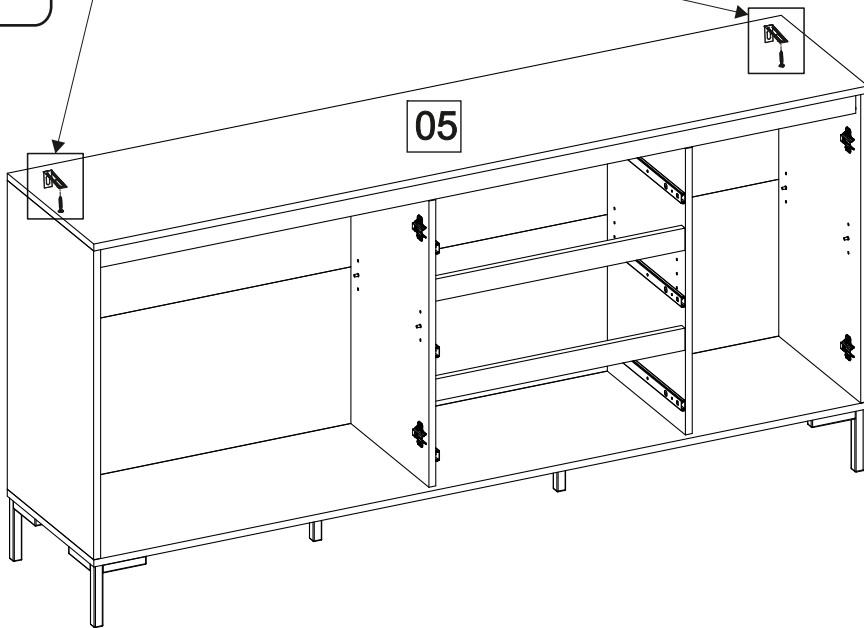
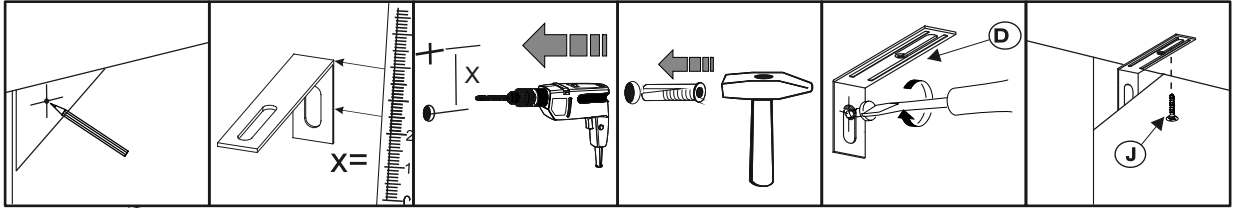

V

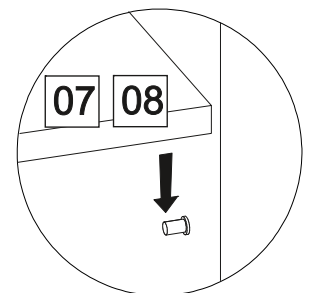
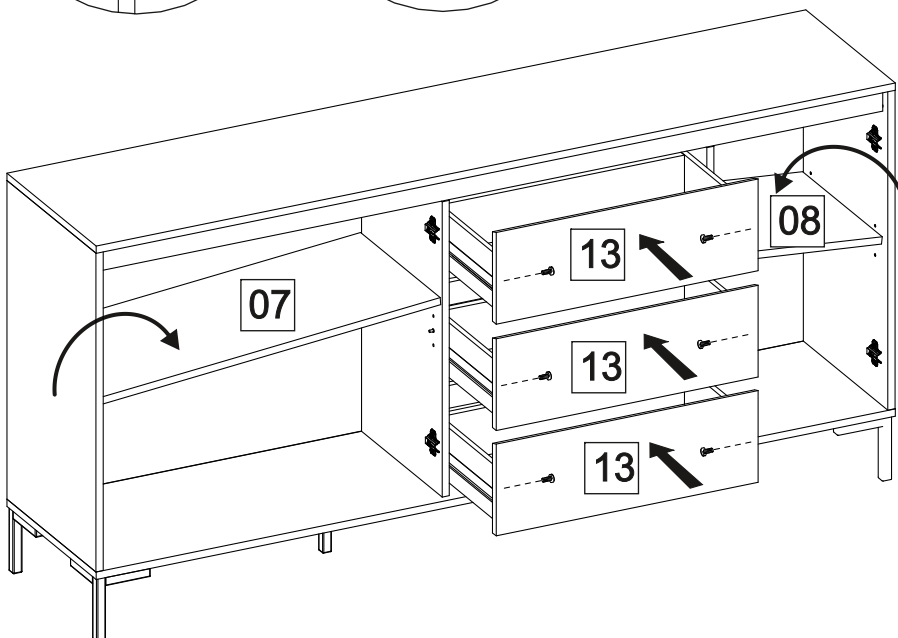
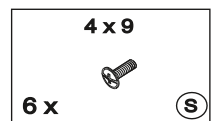
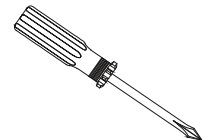
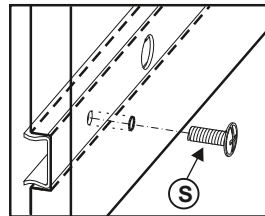
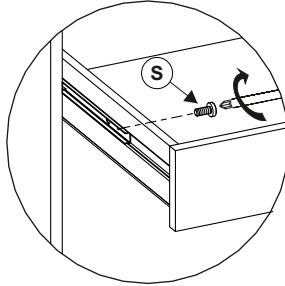
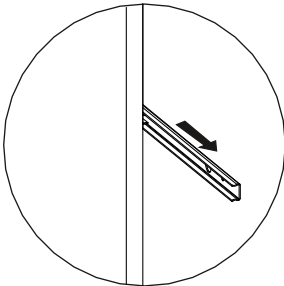

**W**

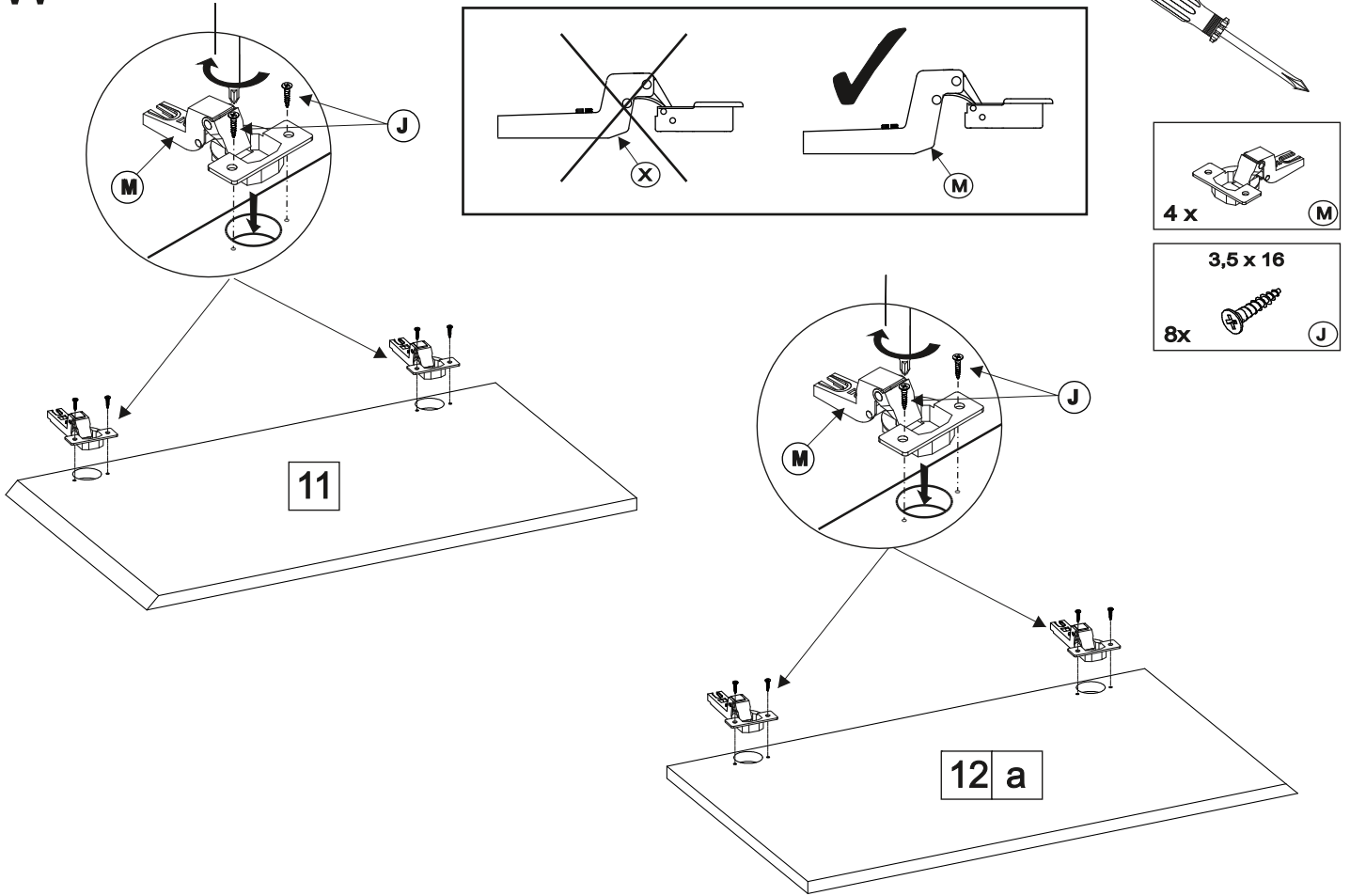

**X**

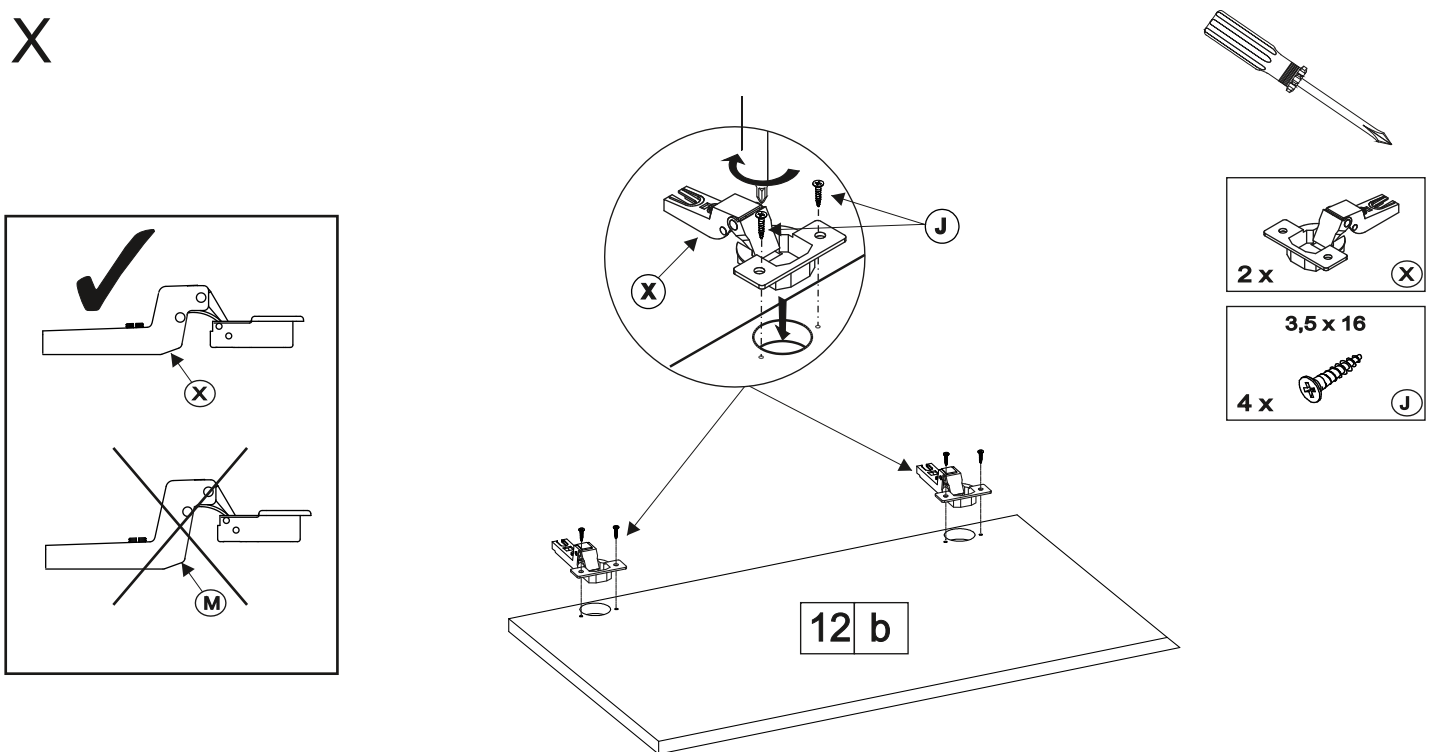



Y

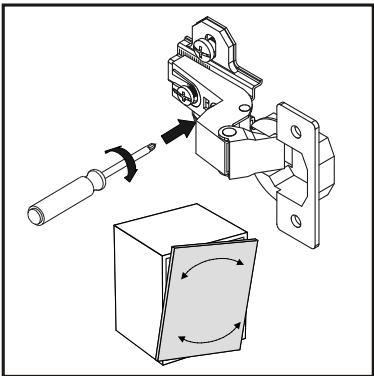
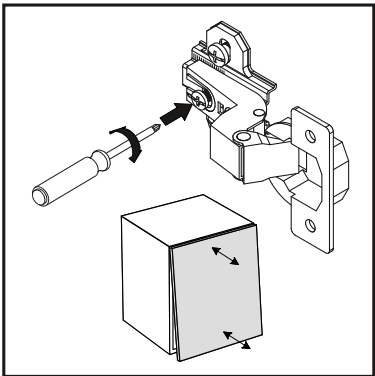
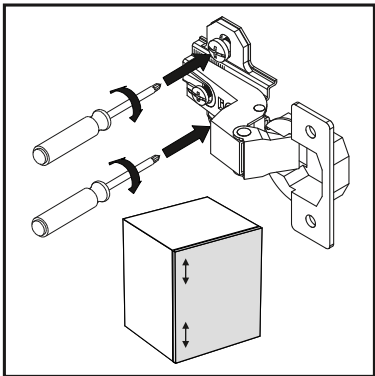
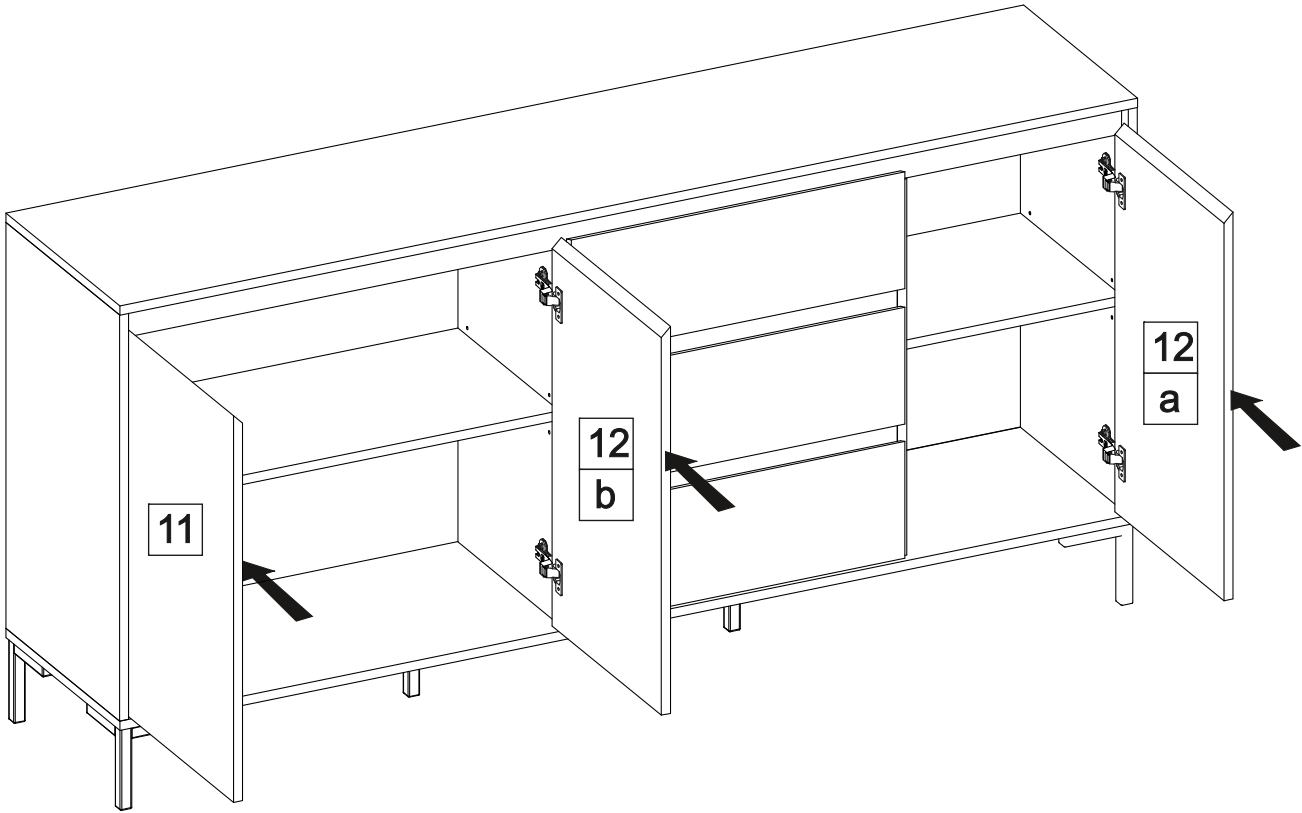
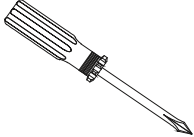
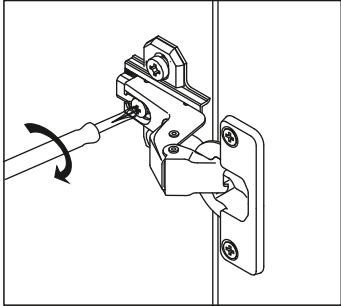
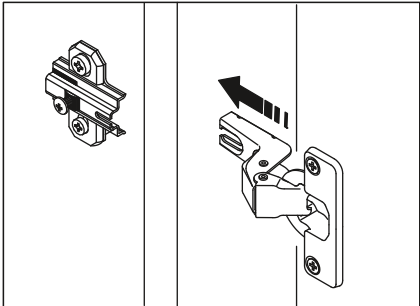



- Ⓓ Das Möbel muss an der Wand befestigt werden!
- Ⓔ Please ensure to mount the furniture to the wall!
- Ⓕ Les meubles doivent être fixés au mur!
- Ⓝ Het meubel moet aan de wand worden vastgemaakt!
- Ⓔ El mueble se tiene que fijar a la pared!
- Ⓜ Mebel należy przymocować do ściany!



- Ⓓ Informieren Sie sich vor der Wandmontage über das geeignete Montagematerial!
- Ⓔ Please get informed on suitable assembly materials before commencing the wall-mounting!
- Ⓕ Renseignez-vous sur le matériel de montage approprié avant le montage mural!
- Ⓝ Informeer u voor de wandmontage over het geschikte montagematerieel!
- Ⓔ Infórmese antes del montaje en la pared del material apropiado de montaje!
- Ⓜ Przed montażem na ścianie upewnij się, jaki jest potrzebny właściwy materiał montażowy!



- Ⓓ Beschaffen Sie sich das angemessene Material zur Wandbefestigung!
- Ⓔ Please obtain suitable wall-mounting materials!
- Ⓕ Procurez-vous le matériel approprié pour le montage mural!
- Ⓝ Verschaf u het adequate materieel voor de wandbevestiging!
- Ⓔ Procúrese el material adecuado para la fijación a la pared!
- Ⓜ Zakup odpowiedni materiał do przymocowania na ścianie!



- Ⓓ Lassen Sie die Wandbefestigung von einer fachkundigen Person vornehmen!
- Ⓔ Ensure all wall-mounting is carried out by competent personnel!
- Ⓕ Faites effectuer le montage mural par une personne compétente!
- Ⓝ Laat de wandbevestiging door een professional uitvoeren!
- Ⓔ Deje que la fijación a la pared la haga un profesional!
- Ⓜ Zleć przymocowanie do ściany odpowiednio doświadczonej osobie!

- Ⓜ Мебель должна крепиться к стене!
- Ⓙ Il mobile deve essere fissato alla parete!
- Ⓜ A bútor a falon rögzítendő!
- Ⓜ O móvel tem que ser fixado na parede!
- Ⓒ Nábytek musí být připevněn ke stěně!

- Ⓜ Перед тем, как крепить мебель к стене, получите информацию о подходящем крепежном материале!
- Ⓙ Prima del fissaggio alla parete, informarsi sul materiale di montaggio adatto!
- Ⓜ A falra szerelés előtt tájékozódjon, hogy ehhez milyen szerelőanyagok szükségesek!
- Ⓜ Antes da montagem na parede, informe-se sobre o material de montagem adequado!
- Ⓒ Informujte se o vhodném montážním materiálu před montáží na stěnu!

- Ⓜ Приобретите соответствующий материал для крепления к стене!
- Ⓙ Procurarsi il materiale opportuno per il fissaggio alla parete!
- Ⓜ Szerezze be a falra szereléshez szükséges, megfelelő anyagokat!
- Ⓜ Obtenha o material adequado para a montagem na parede!
- Ⓒ Opatřte si vhodný materiál pro montáž na stěnu!

- Ⓜ Поручите выполнение работ по креплению к стене специалисту!
- Ⓙ Far effettuare il fissaggio alla parete ad un esperto!
- Ⓜ A bútor falra rögzítését végeztesse ehhez értő személlyel!
- Ⓜ A montagem na parede deve ser executada por uma pessoa competente!
- Ⓒ Montáž na stěnu nechte provést odborně způsobilou osobou!

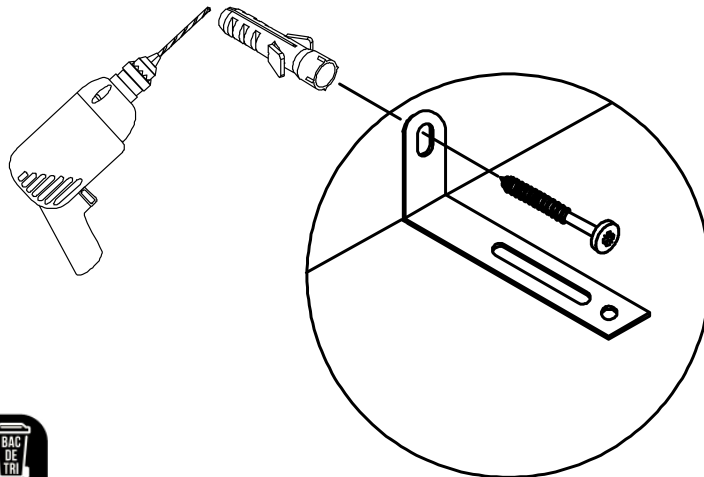
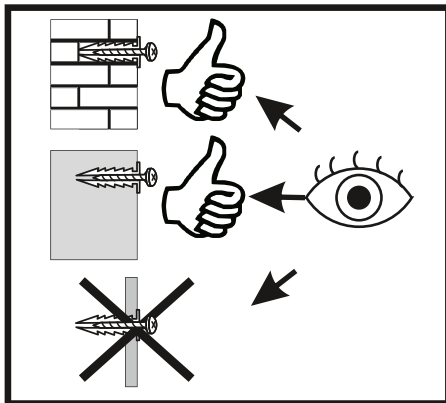

<https://quefairedemesdechets.fr>